

STC METROPOLITAN DISTRICT NO. 2

141 Union Boulevard, Suite 150
Lakewood, Colorado 80228-1898
Tel: 303-987-0835 · 800-741-3254
Fax: 303-987-2032

NOTICE OF REGULAR MEETING AND AGENDA

<u>Board of Directors:</u>	<u>Office:</u>	<u>Term/Expires:</u>
James A. Brzostowicz	President	2020/May 2020
Angie Hulsebus	Treasurer	2020/May 2020
<i>VACANT</i>		2022/May 2022
<i>VACANT</i>		2022/May 2020
<i>VACANT</i>		2020/May 2020
Lisa A. Johnson	Secretary	

DATE: June 5, 2019
TIME: 9:00 A.M.
PLACE: McGeady Becher P.C.
450 E. 17th Ave., Suite 400
Denver, CO 80203

I. ADMINISTRATIVE MATTERS

- A. Present Disclosures of Potential Conflicts of Interest.
-

- B. Approve Agenda, confirm location of the meeting and posting of meeting notices.
-

II. CONSENT AGENDA

- Approve Minutes of the May 1, 2019 Regular Meeting (enclosure).
 - Ratify approval of Change Order No. 3, Superior Town Center Block 25 Phase 2 under the contract between the District and SAMORA Construction to Reclaim Water Line, for an increase in the Construction Contract amount of \$34,756.25.
-

III. FINANCIAL MATTERS

- A. Review and ratify approval of payment of claims for the following period (enclosure):

Fund	Period Ending May 23, 2019
General	\$ 14,493.35
Debt	\$ -0-
Capital	\$ 6,244.09
Total	\$ 20,737.44

B. Review and accept unaudited financial statements through the period ending April 30, 2019 (enclosure).

C. Discuss status of 2018 Audit.

D.

IV. LEGAL MATTERS

A. Discuss status of 2019 Refunding and Improvement Bonds

V. OPERATIONS AND MAINTENANCE

A. Status of additional pet waste stations to be installed.

B.

VI. COVENANT CONTROL

A. Review Community Manager's Report (enclosure).

VII. CAPITAL PROJECTS

A. Review and consider approval of improvement costs in the amount of \$2,993,588.74 under that certain Final Engineers Report and Certification #48 prepared by Ranger Engineering, LLC, dated May 24, 2019 (enclosure).

B.

VIII. DEVELOPER UPDATE

- A. Status of lot and home sales.
-

IX. OTHER MATTERS

- A. Consider appointments of Terry Willis and Lee Merritt to the Board of Directors after publication of Notice of Vacancy in the Boulder Daily Camera on May 10, 2019. Administer Oaths of Office.
-

- B. Consider appointment of Officers:

President _____
Treasurer _____
Secretary _____
Asst. Secretary _____
Asst. Secretary _____
Asst. Secretary _____

- X. ADJOURNMENT **THE NEXT REGULAR MEETING IS SCHEDULED FOR JULY 3, 2019.**

RECORD OF PROCEEDINGS

MINUTES OF A REGULAR MEETING OF THE BOARD OF DIRECTORS OF THE STC METROPOLITAN DISTRICT NO. 2 HELD MAY 1, 2019

A Regular Meeting of the Board of Directors (referred to hereafter as the “Board”) of the STC Metropolitan District No. 2 (referred to hereafter as the “District”) was convened on Wednesday, the 1st day of May, 2019, at 9:00 A.M., at the offices of McGeady Becher P.C., 450 E. 17th Avenue, Suite 400, Denver, Colorado. The meeting was open to the public.

ATTENDANCE

Directors In Attendance Were:

James A. Brzostowicz
Angie Hulsebus

Also In Attendance Were:

Lisa A. Johnson; Special District Management Services, Inc. (“SDMS”)

Megan Becher, Esq. and Kate Olson; Esq.; McGeady Becher P.C.

Mark Chambers; Simmons & Wheeler, P.C.

Sonia Chin, Bill Jencks, and Jessica Sergi; Ranch Capital, LLC (via speakerphone)

Dave Andrews; Edifice, LLC

DISCLOSURE OF POTENTIAL CONFLICTS OF INTEREST

Disclosure of Potential Conflicts of Interest: The Board noted it was in receipt of disclosures of potential conflicts of interest statements for each of the Directors and that the statements had been filed with the Secretary of State at least seventy-two hours in advance of the meeting. Ms. Johnson requested that the Directors review the Agenda for the meeting and advised the Board to disclose any new conflicts of interest which had not been previously disclosed. No further disclosures were made by Directors present at the meeting.

ADMINISTRATIVE MATTERS

Agenda: Ms. Johnson distributed for the Board's review and approval a proposed Agenda for the District's Regular Meeting.

RECORD OF PROCEEDINGS

Following discussion, upon motion duly made by Director Hulsebus, seconded by Director Brzostowicz and, upon vote, unanimously carried, the Agenda was approved, as amended.

Confirm Location of Meeting, Posting of Meeting Notices and Quorum: Ms. Johnson confirmed the presence of a quorum. The Board entered into a discussion regarding the requirements of Section 32-1-903(1), C.R.S., concerning the location of the District's Board meeting.

Following discussion, upon motion duly made by Director Hulsebus, seconded by Director Brzostowicz and, upon vote, unanimously carried, the Board determined that because there was not a suitable or convenient location within the District's boundaries, within the County which the District is located, or within 20 miles of its boundaries to conduct this meeting, the meeting would be conducted at the above-stated location. The Board further noted that the notice of the time, date and location of the meeting was duly posted and that no objections to the location or any requests that the meeting place be changed were received from taxpaying electors within the District's boundaries.

CONSENT AGENDA

The Board considered the following actions:

- Approve Minutes of the April 3, 2019 Regular Meeting.
- Ratification of Change Order No. 11R1 and Change Order No. 12R2 with Hudick Excavating, Inc. for the Superior Town Center Discovery Parkway FD1, Phase 2.

Following discussion, upon motion duly made by Director Brzostowicz, seconded by Director Hulsebus and, upon vote, unanimously carried, the Board approved and/or ratified approval of, as appropriate, the above actions, as presented.

FINANCIAL MATTERS

Claims: The Board considered approval of the payment of claims as follows:

Fund	Period Ending Apr. 24, 2019
General	\$ 24,428.64
Debt	\$ 4,000.00
Capital	\$ 7,216.95
Total	\$ 35,645.59

Following discussion, upon motion duly made by Director Brzostowicz, seconded by Director Hulsebus and, upon vote, unanimously carried, the Board ratified approval of the payment of claims, as presented.

RECORD OF PROCEEDINGS

Unaudited Financial Statements: Mr. Chambers presented the unaudited financial statements for the period ending March 31, 2019.

Following discussion, upon motion duly made by Director Brzostowicz, seconded by Director Hulsebus and, upon vote, unanimously carried, the Board accepted the unaudited financial statements for the period ending March 31, 2019.

LEGAL MATTERS

Request from Aweida Properties Regarding Recordation of Covenants, Conditions, and Restrictions: Attorney Becher reported to the Board that she has provided the Master Declaration of Covenants, Conditions, and Restrictions for Superior Town Center to Mr. Aweida. Mr. Aweida will work with his attorney, Mr. Matt Dalton, Esq., of Spencer Fane LLP to prepare their own covenant that is essentially the same. The District will be enforcing the covenant and needs to review the draft.

Closure of Notice of Violation/Cease and Desist Order, Number S0-161006-1, Compliance Order on Consent, Number SC-190311-1, and Order for Civil Penalty, Number SP-190322-1 from Colorado Department of Public Health and Environment's ("CDPHE") Water Quality Control Division: Ms. Johnson reported that the fine has been paid and the violation has been closed and no further action is required.

OPERATIONS / MAINTENANCE

Additional Pet Waste Stations: Homeowner, Denise Bruder, inquired about additional pet waste stations. It was noted that they have been ordered and will be installed when received. Ms. Bruder also inquired about the following:

- Putting "No Term Parking" signs in the alley
- Weed problems
- Driveways and sidewalks being deteriorated by salt

Ms. Ripko reviewed these concerns and gave direction for follow-up on these matters.

Resident, Don Breit, at 2322 Marigold Place Regarding Drainage Issue: The Board reviewed the request of Mr. Breit at 2322 Marigold Place regarding drainage issue. The Board acknowledged there is a problem and it will begin working with its contractor to resolve the issue. One option discussed is to extend the pipe or chase (drain) to the resident's property line.

RECORD OF PROCEEDINGS

COMMUNITY MANAGEMENT/ COVENANT CONTROL

Community Management Report: Ms. Johnson presented to the Board the Community Manager's Report. It was determined that a courtesy letter on trash can violations will be sent out.

Resolution No. 2019-05-01; First Amended and Restated Residential Rules, Regulations, and Design Guidelines: The Board discussed Resolution No. 2019-05-01; First Amended and Restated Residential Rules, Regulations, and Design Guidelines. Ms. Johnson will post this on the District's website.

Following discussion, upon motion duly made by Director Brzostowicz, seconded by Director Hulsebus and, upon vote, unanimously carried, the Board adopted Resolution No. 2019-05-01; First Amended and Restated Residential Rules, Regulations, and Design Guidelines.

CAPITAL PROJECTS

Final Engineer's Report and Certification #47 dated April 25, 2019: Ms. Johnson reviewed with the Board the improvement costs under the Final Engineer's Report and Certification #47, dated April 25, 2019, prepared by Ranger Engineering, LLC.

Following discussion, upon motion duly made by Director Brzostowicz, seconded by Director Hulsebus and, upon vote, unanimously carried, the Board accepted the improvement costs in the approximate amount of \$288,250.21 under that certain Final Engineer's Report and Certification #47, dated April 25, 2019, prepared by Ranger Engineering, LLC.

Dry Utilities for Aweida Discovery Townhomes inside Block 25 Outlot: Director Brzostowicz presented to the Board. It was noted that dry utility pedestals were recently installed and that the District plans to accept maintenance responsibilities once the District reviews and accepts the plan for landscape improvement design.

Following discussion, upon motion duly made by Director Brzostowicz, seconded by Director Hulsebus and, upon vote, unanimously carried, the Board acknowledged the dry utility improvements and accepted maintenance responsibilities subject to the District's review of the plan for landscape improvement design.

Change Order No. 001-Revision 1, Superior Town Center Block 25 Phase 2 under the Construction Contract between the District and SAMORA Construction for Block 26 Pricing- Redland Plans: The Board discussed and reviewed Change Order No. 001-Revision 1, Superior Town Center Block 25 Phase 2 under the Construction Contract between the District and SAMORA Construction for Block 26 Pricing- Redland Plans.

RECORD OF PROCEEDINGS

Following discussion, upon motion duly made by Director Brzostowicz, seconded by Director Hulsebus and, upon vote, unanimously carried, the Board approved Change Order No. 001-Revision 1, Superior Town Center Block 25 Phase 2 under the Construction Contract between the District and SAMORA Construction for Block 26 Pricing- Redland Plans, for an increase in the Construction Contract amount of \$369,038.98.

Change Order No. 2 Revision 1, Superior Town Center Block 25 Phase 2 under the Construction Contract between the District and SAMORA Construction for an Extension of Time to Complete Work due to Weather Delay: The Board discussed and reviewed Change Order No. 2 Revision 1, Superior Town Center Block 25 Phase 2 under the Construction Contract between the District and SAMORA Construction for an extension of time to complete work due to weather delay.

Following discussion, upon motion duly made by Director Brzostowicz, seconded by Director Hulsebus and, upon vote, unanimously carried, the Board approved Change Order No. 2 Revision 1, Superior Town Center Block 25 Phase 2 under the contract between the District and SAMORA Construction for an extension of time to complete work due to weather delay.

Change Order No. 3 Superior Town Center Block 25 Phase 2 under the Construction Contract between the District and SAMORA Construction to Reclaim Water Line: The Board discussed and reviewed Change Order No. 3 Superior Town Center Block 25 Phase 2 under the Construction Contract between the District and SAMORA Construction to Reclaim Water Line.

Following discussion, upon motion duly made by Director Brzostowicz, seconded by Director Hulsebus and, upon vote, unanimously carried, the Board approved Change Order No. 3, Superior Town Center Block 25 Phase 2 under the contract between the District and SAMORA Construction for Reclaim Water Line, for an increase in the Construction Contract amount of \$34,756.25.

DEVELOPER UPDATE

Lot and Home Sales: Mr. Jencks provided a brief update to the Board on lot and home sales.

OTHER MATTERS

Request from Resident for the District Manager and Community Manager to attend Homeowners Social: A request was made from a resident for the District Manager and Community Manager to attend an upcoming Homeowners Social. The Board directed staff to attend the event and to answer questions regarding the District.

RECORD OF PROCEEDINGS

Ms. Sowash Expressed Landscaping Concerns Regarding Courtyard and Location of her Downspout: The Board took note of Ms. Sowash's landscaping concerns regarding the courtyard. Ms. Johnson noted that she will obtain the address and send to Director Brzostowicz and Mr. Andrews for response. Ms. Johnson will also follow-up regarding the homeowner's downspout concerns.

ADJOURNMENT

There being no further business to come before the Board at this time, upon a motion duly made, seconded, and, upon vote, unanimously carried, the meeting was adjourned.

Respectfully submitted,

By _____
Secretary for the Meeting

THESE MINUTES ARE APPROVED AS THE OFFICIAL MAY 1, 2019
REGULAR MEETING MINUTES OF THE STC METROPOLITAN DISTRICT
NO. 2 BY THE BOARD OF DIRECTORS SIGNING BELOW:

James A. Brzostowicz

Angie Hulsebus

Terry Willis

Lee Merritt

RESOLUTION NO. 2019-05-01

RESOLUTION OF THE BOARD OF DIRECTORS OF STC METROPOLITAN DISTRICT NO. 2 ADOPTING THE FIRST AMENDED AND RESTATED SUPERIOR TOWN CENTER RULES, REGULATIONS AND DESIGN GUIDELINES

1. STC Metropolitan District No. 1 (“**District No. 1**”), STC Metropolitan District No. 2 (“**District No. 2**”) and STC Metropolitan District No. 3 (“**District No. 3**”) (each a “**District**” and, collectively, the “**Districts**”) are quasi-municipal corporations and political subdivisions of the State of Colorado located in the Town of Superior (the “**Town**”), Boulder County (the “**County**”), Colorado.

2. The Districts were organized pursuant to Service Plans approved by the Town on May 13, 2013, as may be amended and/or modified from time to time (“**Service Plans**”).

3. Pursuant to Section 32-1-1001(1)(m), C.R.S., the Districts have the power “to adopt, amend and enforce bylaws and rules and regulations not in conflict with the constitution and laws of this state for carrying on the business, objects, and affairs of the board and of the special district.”

4. Pursuant to Section 32-1-1001(1)(j)(I), C.R.S., the Districts have the power “to fix and from time to time to increase or decrease fees, rates, tolls, penalties or charges for services, programs, or facilities furnished by the special district.”

5. RC Superior, LLC, a Delaware limited liability company (the “**Developer**”), has caused to be recorded the Master Declaration of Covenants, Conditions and Restrictions, dated April 13, 2015, and recorded in the real property records of the County as Reception No. 3439339, as the same may be amended and/or modified from time to time (the “**Covenants**”) and applicable to the real property within the District (the “**Property**”).

6. The Property encumbered by the Covenants either is, or is anticipated to be included within the boundaries of one of the Districts.

7. The Covenants provides that one or more of the Districts shall enforce each of the provisions provided therein.

8. Section 32-1-1004(8), C.R.S., authorizes the Districts to furnish covenant enforcement and design review services within the District if the declaration, rules and regulations, or similar document containing the covenants to be enforced for the area within the metropolitan district name the metropolitan district as the enforcement or design review entity.

9. Pursuant to the Covenants, the Districts have the right to send demand letters and notices, to levy and collect fines, to negotiate, to settle, and to take any other actions with respect to any violation(s) or alleged violation(s) of the Covenants.

10. The Covenants provide for the Superior Town Center Rules, Regulations and Design Guidelines (the “**Rules, Regulations and Guidelines**”) to be promulgated, amended, revised from time to time, administered and enforced by the Districts.

11. The Districts entered into that certain Facilities Funding, Construction and Operation Agreement (the “**FFCOA**”), dated January 15, 2015, pursuant to which the Districts agreed that District No. 2 is the Operating District responsible for all operations and maintenance services for the Districts.

12. The Districts entered into that certain Intergovernmental Agreement for Covenant Enforcement and Design Review (the “**IGA**”), dated June 7, 2017, pursuant to which the Districts authorized District No. 2 to administer and enforce the Covenants and the Rules, Regulations and Guidelines for the Property.

13. The Boards of Directors for the Districts jointly adopted the IGA and acknowledged District No. 2’s authority to administer and enforce the Covenants and the Rules, Regulations and Guidelines for the Property.

14. District No. 2 previously adopted that certain Resolution 2017-06-01, Resolution of the Board of Directors of Superior Town Center Metropolitan District No. 2 Adopting the Superior Town Center Rules, Regulations and Design Guidelines.

15. District No. 2 previously adopted that certain Resolution 2018-04-01, Resolution of the Board of Directors of Superior Town Center Metropolitan District No. 2 Adopting the First Amendment to the Superior Town Center Rules, Regulations and Design Guidelines.

16. The Superior Town Center Rules, Regulations and Design Guidelines have now been amended and restated to include information on solar energy devices and sunshades and are now entitled, First Amended and Restated Superior Town Center Rules, Regulations and Design Guidelines (the “**First Amended and Restated Rules, Regulations and Design Guidelines**”).

17. District No. 2 desires to replace the Rules, Regulations and Design Guidelines with the First Amended and Restated Rules, Regulations and Design Guidelines.

18. District No. 2 desires to provide for the orderly and efficient enforcement of the Covenants by adopting the First Amended and Restated Rules, Regulations and Design Guidelines.

NOW, THEREFORE, BE IT RESOLVED BY THE BOARD OF DIRECTORS OF THE STC METROPOLITAN DISTRICT NO. 2:

1. The Board of Directors of District No. 2 hereby adopts the First Amended and Restated, Regulations and Design Guidelines as described in **Exhibit A**, attached hereto and incorporated herein by this reference.

2. The Board of Directors of District No. 2 declares that the First Amended and Restated Rules, Regulations and Design Guidelines are effective as of May 1, 2019.

3. Judicial invalidation of any of the provisions of this Resolution or of any paragraph, sentence, clause, phrase or word herein, or the application thereof in any given circumstances, shall not affect the validity of the remainder of this Resolution, unless such invalidation would act to destroy the intent or essence of this Resolution.

[SIGNATURE PAGE FOLLOWS]

[SIGNATURE PAGE TO RESOLUTION NO. 2019-05-01

APPROVED AND ADOPTED this 1st day of May, 2019.

STC METROPOLITAN DISTRICT NO. 2

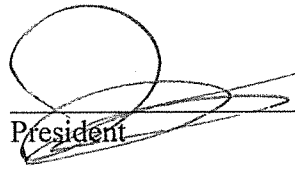
By: 
President

Attest:



Secretary or Assistant Secretary

EXHIBIT A

**FIRST AMENDED AND RESTATED SUPERIOR TOWN CENTER RULES,
REGULATIONS AND DESIGN GUIDELINES**

ADOPTED AND EFFECTIVE MAY 1, 2019

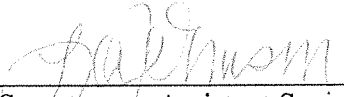
**FIRST AMENDED AND
RESTATED SUPERIOR TOWN
CENTER RESIDENTIAL
RULES, REGULATIONS AND
DESIGN GUIDELINES**

STC Metropolitan District No. 2

The Board of Directors of STC Metropolitan District No. 2 (the “District”)¹ adopted these Superior Town Center Rules, Regulations and Design Guidelines (“Guidelines”) to be read in conjunction with the Master Declaration of Covenants, Conditions and Restrictions for Superior Town Center (“Declaration”) to give direction to Owners and residents before the construction, installation, erection, or alteration of any structure, facility and appurtenance of any kind located on any Residential Lot within Superior Town Center is made.

This First Amended and Restated document replaces, in full, previous Guidelines.

This document incorporates the following:

Document History:

- Superior Town Center Residential Rules, Regulations and Design Guidelines (adopted June 7, 2017, Resolution No. 2017-06-01) (Replaced and Superseded)
- First Amendment to the Superior Town Center Residential Rules, Regulations and Design Guidelines (adopted April 4, 2018, Resolution No. 2018-04-01) (Replaced and Superseded)

¹ Pursuant to that certain Intergovernmental Agreement Regarding Covenant Enforcement and Design Review Services, between the District, STC Metropolitan District No. 1 (“District No. 1”), and STC Metropolitan District No. 3 (“District No. 3”) (collectively, the “Districts”), the Districts authorized and designated the Board of Directors of the District to exercise the powers of the Districts with respect to the provision of covenant enforcement and design review services, and therefore, District No. 1 and District No. 3 are also subject to these Guidelines.

TABLE OF CONTENTS

	Page
SECTION 1 INTRODUCTION AND BASES FOR GUIDELINES	1
1.01 Introduction.....	1
1.02 Bases for Guidelines and Interpretation.....	1
SECTION 2 DEFINITIONS	2
SECTION 3 PROCESSES FOR DESIGN REVIEW AND APPROVAL	2
3.01 Design Review Committee	2
3.02 Who Is Subject to These Guidelines?	2
3.03 Design Review Requests.....	3
3.04 Applicant Action Following Approval	5
SECTION 4 ENFORCEMENT	5
4.01 Covenant Enforcement Committee.....	5
4.02 Violations.....	5
4.03 Notice of Violations.....	5
4.04 Class I Violation	5
4.05 Class II Violation	6
4.06 Penalties	6
4.07 Procedure for Hearing.....	6
SECTION 5 PRIVATE LANDSCAPE GUIDELINES AND REQUIREMENTS	6
5.01 Private Landscape Requirements.....	7
5.02 Drought Tolerant Planting	8
5.03 Irrigation Requirements	8
5.04 Maintenance Requirements.....	8
5.05 Softscape Elements and Materials Requirements	8
5.06 Timing for Landscaping Improvements.....	8
5.07 Trees and Shrubs.....	8
5.08 Views and Screening.....	9
SECTION 6 FENCING GUIDELINES	9
SECTION 7 SPECIFIC TYPES OF IMPROVEMENTS - GUIDELINES	10
7.01 Accessory and Shed Structures.....	10
7.02 Air Conditioners.....	10
7.03 Antennas/Satellite Dishes	11
7.04 Architectural Elements.....	11
7.05 Basketball Backboards.....	11
7.06 Building Height Limit.....	11
7.07 Decks, Patios, and Walkways/Paths	11
7.08 Elevation Treatments	12
7.09 Enclosures, Shelters, and Dog Runs	12
7.10 Exterior Colors and Materials.....	12
7.11 Exterior Lighting.....	13
7.12 Exterior Mechanical Equipment	13
7.13 Foundations.....	13
7.14 Front Yard Improvements/Modifications	13
7.15 Garages	13
7.16 Holiday Decorations and Flags/Flagpoles	13

7.17	Home Selection Guidelines.....	14
7.18	House Address Numbers.....	14
7.19	Parking Areas.....	14
7.20	Play Structures	14
7.21	Rain Barrels	15
7.22	Roof Slope	15
7.23	Siding and Trim	15
7.24	Signs.....	15
7.25	Site Considerations	15
7.26	Solar Energy Devices.....	16
7.27	Spas and at-grade Swimming Pools.....	16
7.28	Storm Doors	17
7.29	Sunshades.....	17
7.30	Trampolines	17
7.31	Trash/Garbage and Recycling Receptacles and Service.....	17
7.32	Windows	18

LIST OF EXHIBITS

- EXHIBIT A** Fencing Examples
- EXHIBIT B** Plant Lists
- EXHIBIT C** Exterior Color Schemes

APPENDICES

- APPENDIX I** Design Review Request Instructions
- APPENDIX II** Antenna/Satellite Dish Rules and Regulations

SECTION 1 INTRODUCTION AND BASES FOR GUIDELINES

1.01 Introduction.

These Guidelines have been adopted by the Board of Directors of the District to assist Residential Owners in the design and construction of home additions or alterations, and installation of Improvements within Property served by the District. These Guidelines provide Residential Owners with design direction so that any Improvements will be visually consistent and architecturally compatible with the overall community theme, in accordance with the Declaration recorded against the Property within the Superior Town Center community.

The purpose and intent of these Guidelines is to assure Residential Owners that proper standards of development and construction will be maintained for the benefit of all and have been adopted by the District pursuant to the Declaration.

The intent of the Declaration and these Guidelines is to create a neighborhood community of high quality development and construction in which the natural character of the area is preserved and maintained, and in which the construction of Improvements is visually consistent and architecturally compatible with the overall community theme. The general theme of the Superior Town Center community is a blend of “Contemporary”, “19th Century Urban/Industrial”, and “Craftsman” architectural forms.

The intent of these Guidelines is to establish a community that achieves harmony among homes and between each home and the surrounding landscape, yet allows individual identity to the home. The purpose and goals of these Guidelines are to:

- A. Assure compatibility and harmony of exterior color, materials and design so the exteriors of the structures are complementary and avoid negative contrast within the neighborhood.
- B. Relate proposed improvements to the natural features of the land and to the neighboring structures and other improvements.
- C. Maintain sustainable, diversified landscaping that is water efficient.
- D. Conform to the plans and overview of the Superior Town Center Documents.

1.02 Bases for Guidelines and Interpretation.

(a) Declaration. The Declaration governs all Properties within Superior Town Center. A copy of the Declaration is available at any time from the District. The Declaration is also recorded in the real property records of Boulder County, Colorado. Each Owner should review and become familiar with the Declaration. Nothing in these Guidelines supersedes or alters the provisions or requirements of the Declaration and, if there is any conflict or inconsistency between these Guidelines and the Declaration, the Declaration controls.

(b) Governmental and Other Regulations. Use of Property and Improvements must comply with the applicable building codes or other governmental requirements and regulations.

Where the provisions of applicable federal, state, Boulder County and/or Town of Superior standards are more restrictive than the provisions of these Guidelines, such other more restrictive standards shall control.

(c) Variances. The DRC reserves the right to vary at any time from procedure or standards as established herein. The District reserves the right to amend, supplement or repeal these Guidelines at any time.

(d) Zoning Ordinance and Declarations. Additional standards and requirements are set forth in the Declaration, Plat, and the Superior Town Center Documents. Each Owner must read and become familiar with all such documents, thus avoiding violations of the standards and requirements set forth therein. Copies of the Plat and Superior Town Center Documents are available from the DRC.

SECTION 2 DEFINITIONS

Any term not defined herein shall have the same meaning as contained in Definitions section of the Declaration.

SECTION 3 PROCESSES FOR DESIGN REVIEW AND APPROVAL

3.01 Design Review Committee.

Article 5 of the Declaration provides for the creation of the Design Review Committee (“DRC”), which is responsible for: administrating the application of these Guidelines; review, approval or rejection of plans for proposed Improvements; and authorization of variances from these Guidelines.

3.02 Who Is Subject to These Guidelines?

Any Residential Owner and/or his/her contractor designing to undertake any modification, addition or alteration relative to any Improvement within the Property is responsible for complying with these Guidelines and initiating the review and obtaining the approvals required by these Guidelines before any such modification is undertaken.

Any additions to or alterations of Improvements after initial approval and installation will require submittal to and approval by the DRC. The DRC should be contacted with any submittal questions and the DRC will advise the applicant if DRC approval is required.

DESIGN REVIEW SUBMITTAL IS REQUIRED UNLESS EXPLICITLY STATED OTHERWISE IN THESE GUIDELINES – ANY IMPROVEMENT THAT DOES NOT COMPLY WITH THE DECLARATION AND THESE GUIDELINES SHALL NOT BE CONSTRUCTED, ERECTED, PLACED, ALTERED, PLANTED, APPLIED, INSTALLED OR MODIFIED UPON ANY RESIDENTIAL LOT, UNLESS OTHERWISE APPROVED BY THE DRC.

3.03 Design Review Requests.

(a) Design Review Instructions and Request Form. Design Review Request Instructions and a Design Review Request Form can be found under **Appendix I**. To make a request for design review, complete the Design Review Request Form and submit it with payment of the appropriate fee and all necessary back-up documents.

Design review requests can be made via US Mail or email to:

STC Metropolitan District No. 2
141 Union Blvd., Suite 150
Lakewood, CO 80228
Phone Contact: 303- 987-0835

(b) Design Review Fee Schedule.

<u>Fee Description</u>	<u>Fee Amount</u>
Landscape Review and/or Fence Review	\$50
Paint Color Change	\$50
Main Building Addition, Addition of Accessory Building, Shed, Deck, Patio, Site Plan, Footprint (including Driveway) Review	\$100
All other items	\$50

Builders, as defined in the Declaration, are exempt from Design Review Fees.

THE DRC MAY MODIFY THE FEE SCHEDULE WITHOUT NOTICE.

Design Review Fees should be made in person or sent via US Mail to:

STC Metropolitan District No. 2
141 Union Blvd., Suite 150
Lakewood, CO 80228
Phone Contact: 303-987-0835

(c) Action by DRC. The DRC shall review each request for approval and make a decision within sixty (60) days after the complete submission of plans, specifications and other materials and information, which the DRC may require in conjunction therewith. Any request for approval shall be deemed disapproved unless written approval is transmitted within sixty (60) days after the receipt by the DRC of all required fees and materials.

(d) Required Documentation. All Improvements must be made in accordance with the Declaration, these Guidelines, and any applicable Town of Superior regulations and

standards. Please review these referenced documents carefully, and make sure your plans comply with their requirements. Unless specifically exempt pursuant to these Guidelines, all Improvements must be approved by the DRC. Approval by the DRC does not excuse Owner from compliance with the Declaration, Superior Town Center Planned Development zoning, or other Town of Superior regulations and standards. It is the Owner's responsibility to properly apply for building permits and any other applicable government approvals.

(i) Building Plan (for Additions or Building Alterations). A Design Review Request for Additions or Building Alterations shall indicate for all buildings the following, drawn to scale:

(1) Roof Plan: Pitch, valleys, hips, materials and overhang should be indicated.

(2) Floor Plan: Main structures and all accessory structures including balconies, decks and square footage of each floor within the main building and square footage of each accessory out-building should be submitted.

(3) Elevations: All exterior elevations with materials, dimensions, final and original grade lines and finished floor elevations should be clearly indicated.

(4) Sections: Should include finish grade, finish floor and maximum roof height.

(ii) Site and Grade Plan (for Landscaping Improvements and Fencing). A Design Review Request for site and grade plans for landscaping Improvements and Fencing shall include a plot plan drawn to scale, showing in detail the location of main buildings on the lot. Show what you intend to accomplish. Indicate existing conditions as well as the proposed Improvements. For example, if you will be installing rock or bark mulch in planting beds, specify the type, color and size. If you are using edging, specify the type of edging. If you are installing a retaining wall, you must indicate how it will be constructed.

YOU MAY NOT ALTER THE DRAINAGE ON YOUR LOT.

The plot plan shall also include the following:

(1) Legal description; north arrow; name, address and telephone number of owner.

(2) Property lines.

(3) Building envelope dimensions with envelope shown in relation to property lines.

(4) Front, side and backyard dimensions to buildings from property lines.

(5) Drives, parking areas and walkways.

- (6) Square footage of the building footprint for each building.
- (7) Topographic diagram of site in one foot (1') intervals showing existing contours and drainage courses and proposed changes to contours and drainage courses and cut/fill areas.
- (8) Location and elevation of access road and off-street parking lot design, if any, including ingress and egress points.
- (9) Location, elevation and square footage of other Improvements, such as swimming pools and patios.
- (10) Reference to adjoining properties, streets, utility and other easements, drainage courses and reference to buildings on adjoining properties and their uses.

3.04 Applicant Action Following Approval.

Following initial DRC approval, the applicant must complete the Improvement as promptly and diligently as possible, and then notify the DRC of the completion to request final approval. Further details of these requirements can be found in the Declaration. "

SECTION 4 ENFORCEMENT.

4.01 Covenant Enforcement Committee.

Article 6 of the Declaration provides for the creation of the Covenant Enforcement Committee ("CEC"), which is responsible for the ministerial administration and enforcement of the Declaration and these Guidelines.

4.02 Violations.

Violations, as defined in the Declaration, shall be subject to the remedies specified in the Declaration and the Penalties outlined below.

4.03 Notice of Violations.

If the DRC and/or CEC determine that a Violation exists, a Notice of Violation will be sent by the DRC and/or CEC within thirty (30) days of the determination that a Violation is likely to or does exist. The Notice shall identify the particular circumstances or conditions of the Violation and the required action and time period to correct, remedy or remove the Violation. Notices of Violation sent pursuant to the Declaration shall also include the date, time, and place of a hearing, and will be sent no less than fifteen (15) days prior to the date of the hearing.

4.04 Class I Violation.

This Violation will be issued for an offense (in the sole discretion of the DRC and/or CEC) that can be corrected immediately, such as parking, trash, lighting, sound or odor violations. In most cases, Class I Violations will be required to be corrected within seven (7) days of the Notice of

Violation or, if the Notice of Violation was sent pursuant to the Declaration, within the time period specified in the written finding issued by the DRC and/or CEC following a hearing.

4.05 Class II Violation.

This Violation will be issued for an offense (in the sole discretion of the DRC and/or CEC) that *cannot* be corrected immediately, and/or requires plans and specifications to be submitted to the DRC for approval prior to correction of the Violation. Class II Violations can include violations relating to landscaping, construction, and additions to, or modifications of, Improvements. In most cases, Class II Violations will be required to be corrected within thirty (30) days of the Notice of Violation, or if the Notice of Violation was sent pursuant to the Declaration, within the time period specified in the written finding issued by the DRC and/or CEC following a hearing.

4.06 Penalties.

Penalties will be assessed if a Property is not brought into compliance within the assigned timeframe listed on the Notice of Violation or, if applicable, in the written finding issued by the DRC and/or CEC following a hearing. Penalties for Violations will be assessed as follows, and any penalties not paid by the due date will be considered delinquent.

<u>Penalty Description</u>	<u>Penalty Amount</u>
First Offense	No penalty
Second Offense	Fee up to \$100
Third Offense	Fee up to \$250
Continuing Violation	Fee up to \$500 each day the Violation continues (each day constitutes a separate Violation)

4.07 Procedure for Hearing.

On the date and time of the hearing specified in the Notice of Violation sent pursuant to the Declaration, the DRC and/or CEC will hear and consider any information and evidence presented by the Owners and/or all other interested parties. No more than five (5) business days following the hearing, the DRC and/or CEC will make a finding that a Lot is either in compliance or that the Lot is in Violation, or continue the hearing to a date certain for the purpose of obtaining additional information. Upon determining a Violation exists, the DRC and/or CEC will issue a written finding of Violation, which will include a timeframe for correction, not to exceed forty-five (45) days. All decisions of the DRC and/or CEC shall be final.

SECTION 5 PRIVATE LANDSCAPE GUIDELINES AND REQUIREMENTS

Superior Town Center is a model community for planning and design integrity of structure and landscape. From the beginning of the project, the development team has focused on form and creativity through natural topography.

These Guidelines are not intended to hinder in any way unique designs or creative expression by the design professional or the Owner. By establishing requirements for site planning, these Guidelines ensure an overall cohesiveness to the community.

For a comprehensive list of landscape standards, please see the approved Superior Town Center Plant List found in Appendix B of the Superior Town Center Design Guidelines Supplement, approved by the Town of Superior (**Exhibit B** of these Guidelines), as same may be amended by the Town from time to time.

YOU MAY NOT ALTER THE DRAINAGE ON YOUR LOT.

5.01 Private Landscape Requirements

(These Private Landscape Requirements apply to all ground area within private property lines. Please note not all units have formal front/backyards, and in this case, are not required to install/meet the below minimum standards. Any and all landscape installations/improvements or changes **MUST** be submitted and approved by the DRC.)

The below standards for private landscaping are minimum standards, which are required by the DRC for Design Review approval. The Owner is welcome to exceed these standards in the number of trees, bushes and amount of ground coverage. Please note that deviating dramatically from the below standards, or failure to meet these minimum requirements, could result in rejection of the Design Review Request by the DRC.

(a) There shall be a minimum of 100% ground coverage installed and maintained for erosion control in all yard areas. Ground coverage shall be turf, decking or other hardscape, or plant material.

(b) There shall be at least one tree, which shall be from the approved Superior Town Center Plant List found in Appendix B of the Superior Town Center Design Guidelines Supplement, approved by the Town of Superior (**Exhibit B** of these Guidelines).

(c) All work and permitting shall be in accordance with the Town of Superior Zoning and Building Code.

(d) New retaining walls over two feet (2') in height are not permitted.

(e) Berms must have less than a 3:1 slope with the soil stabilized by planting ground cover or rock mulch to prevent runoff and erosion. All soil should be re-seeded by the start of the next planting season. No part of the site is to be left barren.

(f) Any raised planter or garden box may not exceed two feet (2') in height and may only be installed in the Backyard, which shall be defined by the area inside private property lines that is between the home and the Rear Property Line. Rear Property Line means the boundary of private property which is on the opposite side of the home as the front door.

YOU MAY NOT ALTER THE DRAINAGE ON YOUR LOT.

5.02 Drought Tolerant Planting

DRC Approval is required. Using drought tolerant plantings and other water conservation methods of landscaping is encouraged; however, the design must be approved. This type of landscaping uses much less water than typical suburban residential landscape, but large areas of river rock or mulch will not necessarily be allowed in place of green, growing plant material.

5.03 Irrigation Requirements

Irrigation systems shall be preinstalled by the builder. Any changes or additions shall be submitted for approval.

5.04 Maintenance Requirements

Watering and fertilizing, weeding, pruning and tree wound dressing is required. All weed and insect control, which impacts drainage and soil quality, must include appropriate safety flags, and notices must be well-labeled at the time of application. Dead plant material must be removed or replaced within thirty (30) days.

5.05 Softscape Elements and Materials Requirements

Softscape elements are comprised of deciduous and evergreen trees, shrubs and ground covers. Vines, lawns, flowers, perennials grasses and wild flowers, in quality and quantity and size at time of planting, shall be chosen for form, color, environmental appropriateness, and seasonal variety and must be installed per industry standards.

5.06 Timing for Landscaping Improvements

Landscaping Improvements are required to be installed within the first growing season in effect after acquisition of title to the initial homeowner. If the acquisition occurs between the months of October and March, landscaping will be installed in the subsequent spring following such acquisition. The deadline for the spring installation will be June 1. Please ensure submittal of your landscaping plans will allow for the review period of up-to sixty (60) days for approval, taking into consideration your specific conditions as it relates to the installation deadline. Though a Design Review Request may have been submitted, if it has not been approved and the installation completed by the Declaration deadline, the property may receive a Notice of Violation.

5.07 Trees and Shrubs

- (a) Canopy, shade trees, and ornamental trees: Two inch (2") caliper minimum.
- (b) All coniferous trees: Four foot (4') minimum height.
- (c) Ornamental and multi-stem trees: Minimum ten foot (10') height.

- (d) Shrubs must be no smaller than two (2)-gallon container size.

Larger trees are recommended and may be used, as they are visually more desirable.

5.08 Views and Screening

Selection of materials to enhance views from each side is critical. Control should be taken to not mask own views and views of neighbors. Views of entries to properties, privacy screens and less desirable areas must be taken into account in landscape design via masking with plantings and appropriate design measures. The DRC may require specific placement of trees and/or shrubs as necessary to protect view corridors.

SECTION 6 FENCING GUIDELINES

Any additions or modifications to fencing shall be submitted for approval. Approved backyard (as defined in Section 5.01(f)) and side yard fencing, if provided, shall be:

- (a) Minimum height: four feet (4').
- (b) Maximum height: six feet (6').
- (c) Post sizes permitted are: 4x4, 4x6 or 6x6.
- (d) Wing fencing is fencing between two houses as seen from the street. The minimum setback for wing fencing, from front of house to back, shall be six feet (6').
- (e) One three foot (3') gate to open space is permitted.
- (f) Gate feature permitted up to eight feet (8') in height by four feet (4') in width.
- (g) Fencing on lot adjacent to a lot must be on your own property, unless there is an agreement with adjoining property owner.
- (h) Finished side of fence should face the street (or away from your house).
- (i) Only natural wood, vertical privacy fencing with top and bottom rail permitted (Examples 1, 2, or 3 on **Exhibit A**), or wrought iron or wire mesh with wood structure permitted (Examples 4 or 5 on **Exhibit A**) for fences adjacent to open space only. **Exhibit A** shall be followed.
- (j) Fences must be treated with clear waterproof stain or natural stain.
- (k) Any new materials added to existing fencing shall be stained to match existing fencing.
- (l) No chain link or vinyl fencing.

**FRONT YARD FENCING IS NOT PERMITTED EXCEPT BY REVIEW AND
APPROVAL OF DRC.**

**THERE SHALL BE NO FENCE CONSTRUCTED ON ANY LOT THAT HAS LESS
THAN FOUR FEET (4') OF CLEARANCE TO ANY OTHER PERMANENT
STRUCTURE.**

SECTION 7 SPECIFIC TYPES OF IMPROVEMENTS - GUIDELINES

7.01 Accessory and Shed Structures.

All accessory and shed structures REQUIRE SUBMITTAL and approval by the DRC. Structures shall be architecturally compatible with the dwelling. Structures must be screened from street view behind a six-foot (6') backyard (as defined in Section 5.01(f)) wood perimeter fence (Examples 1, 2, or 3 on Exhibit A). No chickens or chicken enclosures/buildings are permitted.

(a) Sheds must be located in the backyard or side yard, and screened from street view behind a six-foot (6') wood perimeter fence (Examples 1, 2, or 3 on Exhibit A). Structures must have a setback of a minimum of five feet (5') from property lines.

(b) Massing and scale, as well as forms, roof pitch, materials, colors, and other detailing must be coordinated with the primary residence on the site (e.g., wood materials painted to match the primary residence).

(c) No metal sheds will be permitted.

(d) Plastic sheds will be permitted for structures five feet (5') or less in height; screened from street view behind a six-foot (6') wood perimeter fence (Examples 1, 2, or 3 on Exhibit A). All structures above five feet (5') in height, and not screened, must be constructed of wood.

(e) In all cases, structures must comply with Town of Superior requirements and permits; must be constructed within the building envelope on a level concrete pad; must not alter drainage patterns of the Site, must not exceed eight feet (8') by ten feet (10') in size (or other configuration not to exceed 80 square feet), and must not exceed seven feet (7') in height at its highest point.

7.02 Air Conditioners.

Air conditioning units DO NOT require submittal and approval by the DRC if the following criteria are met:

(a) Air conditioning units must comply with the requirements of the Declaration.

(b) Air conditioning units must be incorporated into the main building or with other detached structures, and be architecturally compatible (including color) with the residence.

(c) Air conditioning units must be ground mounted and screened from street view by a wing fence or appropriate plantings. If screened from view by a wing fence, the fence must be a minimum of four feet (4') tall.

(d) Units will not be permitted on rooftops or in front of residences, unless installed by original home builder.

(e) If in a window, only flush mount units will be permitted.

(f) All air conditioners must be located as far from the front and side property lines as reasonably possible.

Swamp coolers are permitted so long as they comply with the criteria in this section.

7.03 Antennas/Satellite Dishes.

All satellite and antenna equipment must comply with **Appendix II** of these Guidelines.

7.04 Architectural Elements.

The home site plans and elevations are intended to incorporate specific architectural elements which are consistent with the overall development of Superior Town Center neighborhoods. All modifications to these or any structural elements require DRC review and approval.

7.05 Basketball Backboards.

All basketball backboards are subject to approval by the DRC. Standard size backboards may be approved if erected upon the roof fascia of a garage structure and painted to match the structure. Any free standing boards or boards attached to side of house or side of garage require submittal to and approval by the DRC.

7.06 Building Height Limit.

Building height shall be maintained at original builder height.

7.07 Decks, Patios, and Walkways/Paths.

Decks, patios, and walkways/paths DO NOT require approval by the DRC if the following criteria are met:

(a) A deck, patio, walkway/path shall be located in the backyard (as defined in Section 5.01(f)).

(b) Decks, patios, walkway/paths may be constructed of stone, rock, concrete, wood or any other hardscape material as long as the surface does not exceed eighteen inches (18") above finish grade and decking is not proposed to cover more than 50% of the private backyard area.

(c) Deck and railings, if made of wood material, shall be treated to match fence or home color.

(d) Considerations shall be taken for the location and size of all decks so as not to obstruct the view from adjacent lots.

Decks and patios exceeding eighteen inches (18") above finish grade or exceeding 50% of the backyard area require submittal to the DRC and are considered an "Addition" for the required Design Review Fee due upon submission.

7.08 Elevation Treatments.

Architectural design shall incorporate a consistent level of style and architectural interest on all elevations.

7.09 Enclosures, Shelters, and Dog Runs.

Pet/dog enclosures, houses, shelters, and runs DO NOT require submittal to and approval by the DRC if the following requirements are met:

(a) Pet/dog enclosures, houses, shelters or runs are not permitted in front yards.

(b) Pet/dog enclosure, house, shelter or run shall be screened from street view behind a six foot (6') backyard (as defined in Section 5.01(f)) wood perimeter fence (Examples 1, 2, or 3 on Exhibit A).

(c) Pet/dog houses and shelters shall be painted to match house colors, or if wooden, must be sealed to match fencing.

(d) Pet/dog enclosure, house, shelter, or run shall not exceed four feet (4') in height.

(e) Dog runs shall be maintained at a reasonable and acceptable level of cleanliness.

(f) 100% ground coverage shall be maintained in the backyard as required under Section 5, Private Landscape Guidelines and Requirements.

7.10 Exterior Colors and Materials.

The primary goal of the Guidelines with regard to exterior color and material is to encourage and promote a harmonious blend of color in Superior Town Center neighborhoods. Color combinations should tend to accentuate and contrast the architectural detail. Many times, trim and detail are a contrasting color from the body color. Bold, primary colors are discouraged as body colors. Acceptable colors include neutralized shades of green, gray, blue, sand, soft reds, warm terra cotta, taupes and browns. Other colors require DRC approval. Exterior color schemes must also comply with Appendix C of the Superior Town Center Design Guidelines Supplement, approved by the Town of Superior (Exhibit C of these Guidelines). Any other color schemes require DRC approval.

All projections, including, but not limited to, chimney flues, vents, gutters, down spouts, utility boxes, and porches, shall promote natural materials, and be white, black or dark gray in color, or brick, stone, natural copper, natural zinc, or natural stained wood only.

7.11 Exterior Lighting.

Exterior lighting, which is subdued and whose light source is not visible from adjoining dwellings, is permitted for purposes such as illuminating entrances, decks, driveways and parking areas. Driveway lights on poles or fascia-mounted floodlights are not permitted due to glare onto adjoining properties. Holiday lighting may be regulated by the Town of Superior Municipal Code. Garage lights on townhomes must remain on to light the alley, and therefore are exempt from this provision.

7.12 Exterior Mechanical Equipment.

All exterior mechanical equipment or tanks shall be either incorporated into the overall form of the dwelling or permanently enclosed by a material (other than plant material) and completely screened from street and internal courtyard view.

7.13 Foundations.

No more than twelve inches (12") of exposed concrete may be visible on any elevation.

7.14 Front Yard Improvements/Modifications.

Front yard improvements or modifications (aside from minor additions, which do not alter existing hardscape or softscape elements, such as planting flowers in existing beds) REQUIRE SUBMITTAL to and approval by the DRC. See also Section 5, Private Landscape Guidelines and Requirements.

7.15 Garages.

There shall be a minimum of one, and a maximum of four, fully enclosed garage spaces for each single family dwelling unit. Dimensions for each space shall meet the Town of Superior Municipal Code. It is the intent to minimize the visual impact of garage doors by such measures as, but not limited to, siting of the building, protective overhangs or projections, special door facing materials, landscaping or door design, which blends or enhances the overall architectural statement. Garages may not be converted into living spaces, and are to be used for vehicle parking ONLY and not as an extension of livable space.

7.16 Holiday Decorations and Flags/Flagpoles.

All holiday decorations and lighting may be displayed only on nationally-recognized holidays and shall not be placed earlier than thirty (30) days prior to the start of the holiday and shall be removed no later than thirty (30) days following the holiday.

DRC approval is required for any freestanding flagpole. All flag poles shall be constructed of a permanent material. DRC approval is not required for flagpoles mounted to the front of the

residence. Under no circumstance may the height of the flagpole exceed the height of the roofline of the residence. Flag size cannot exceed five feet (5') in length and three feet (3') in width. Flags and flagpoles shall be replaced as necessary in order to prevent wear and tear. Flags may not be illuminated without prior written approval of the DRC. Any request for lighting must detail the type and location of lighting. Lighting shall be placed so as not to disturb Owners of neighboring Lots.

An Owner or resident may display an additional flag on the inside of a window or door of the home on the Lot. The flag may not be larger than nine inches (9") by sixteen inches (16").

7.17 Home Selection Guidelines.

It is the intent of these Guidelines to not repeat any one detached single-family home design on two adjacent lots. Should a purchaser opt for a combination that includes a home concept on an adjacent lot already reserved with that home design, DRC approval is required. DRC approval may involve architectural modification to preserve individuality. The costs of such modifications shall be at the expense of the Owner requesting the duplication.

7.18 House Address Numbers.

Address numbers shall be used on the dwelling unit. The address number at the dwelling unit shall not exceed, in overall size, a total of ½ square foot for each number (*i.e.*, a three number address shall not be greater than 1.5 square feet).

7.19 Parking Areas.

Off drive parking bays or areas and circular driveways require submittal to, and approval by, the DRC.

The alleys behind the townhomes are designated 'Fire Lanes' and no parking is permitted at any time. This includes the aprons behind the garages. Any vehicles parked in the Fire Lanes are subject to ticketing from the Boulder County Sheriff's Department.

The only designated parking for the townhomes is in the garage of each unit. Parking spaces within the community are designated as visitor parking. Owners using those spaces instead of or in addition to their garage may be towed at the owner's expense. Visitors are not permitted to use the visitor spaces for more than 4 visits within a 7 day period, or any 3 consecutive days. In the event of snow, the visitor parking spaces may be used as snow storage.

7.20 Play Structures.

Play Structures DO NOT require approval by the DRC if the play structure is made of wood, located in the backyard (as defined in Section 5.01(f)) and screened from street view behind a six foot (6') backyard wood perimeter fence (Examples 1, 2, or 3 on **Exhibit A**). Play Structures shall be setback a minimum of five feet (5') from property lines and are not allowed in front yards.

7.21 Rain Barrels.

Rain Barrels DO NOT require approval by the DRC if they comply with Colorado House Bill 16-1005, which allows for a maximum of two (2) rain barrels with a combined capacity of 110 gallons, including sealable lids and screens in order to prevent mosquito breeding and address concerns

Rain Barrels shall be of a color and material complimentary to the surrounding architecture, and shall be fully screened from street and public view behind a six foot (6') backyard wood perimeter fence, or other appropriate screens/plantings per the discretion of the DRC.

7.22 Roof Slope.

Original roof slope and pitch shall be maintained.

7.23 Siding and Trim.

Exterior siding may be brick, wood, painted hardboard, cultured stone, stone, rock, stucco, shingle and composite (not natural wood). See Appendix C of the Superior Town Center Design Guidelines Supplement, approved by the Town of Superior (**Exhibit C** of these Guidelines) for examples of approved architectural colors and materials. Application shall be continuous and consistent on all elevations to achieve a uniform and complete design statement. Change in material/color should occur at internal (concave) corners only.

7.24 Signs.

DRC approval is not required for three (3) signs, ground staked or window mounted, one of which shall be no larger than five (5) square feet per sign face; one of which shall be no larger than three feet (3') by four feet (4'); and one of which shall be no larger than eight inches (8") by eight inches (8"). Such signs may be installed in the front yard or on the backyard fence of the Lot.

One additional sign, not exceeding three feet (3') by four feet (4') in size, may be displayed within the boundaries of an Owner's or resident's Lot, without approval, for forty-five (45) days prior to an election and seven (7) days after the election.

DRC approval is required for any additional signs. No lighted sign will be permitted unless utilized by the Developer and/or a Builder.

7.25 Site Considerations.

The DRC, or its appointed representative, will review each plan for a building in relation to the specific characteristics of the subject lot and its surroundings. The basic objective is to achieve compatibility of the building and other improvements with the subject lot and the immediate surroundings. The site consideration review is specific to the site itself. Location of the main buildings, and any proposed additions, should take into consideration the following:

- (a) Natural and proposed final grade contours.

- (b) Street grades as installed.
- (c) Presence of vegetation, trees and shrubs.
- (d) Existing and final views.
- (e) Privacy of subject and surrounding lots, including building improvements on adjoining lots.
- (f) Access driveways and off-street parking.
- (g) Setback requirements as defined by the Planned Development.
- (h) Site grading and drainage, which minimize required natural grade alterations; drainage accommodation from adjoining lots in such a manner that does not cause soil erosion or impede drainage flows or result in excessive drainage onto adjacent lots.

7.26 Solar Energy Devices

Approval is required in order to review aesthetic conditions. Photovoltaic (PV) Solar panels must lay flat on the roof, meet all applicable safety, building codes and electrical requirements, including solar panels for thermal systems (solar water heaters). The DRC is allowed to request changes as long as they do not significantly increase the cost or decrease the efficiency of the proposed device and panels.

7.27 Spas and at-grade Swimming Pools.

Spas (including saunas, hot tubs) and at-grade swimming pools DO NOT require submittal and approval by the DRC if the following criteria are met:

- (a) Spas and at-grade swimming pools shall be constructed with materials and colors that are harmonious with the architecture of the home.
- (b) Spas and at-grade swimming pools shall be designed as an integral part of any associated deck or patio.
- (c) Spas and at-grade swimming pools shall be located in the side or backyards and screened from street view by a six foot (6') privacy fence (Examples 1, 2, or 3 on **Exhibit A**).
- (d) Consideration must be given to potential noise impacts to neighboring properties.
- (e) Special attention must be given to the safety of private spas and swimming pools.
- (f) Any fencing determined to be necessary shall abide by all setbacks and fencing guidelines.
- (g) Above-grade swimming pools require DRC approval.

7.28 Storm Doors.

Storm doors DO NOT require submittal to and approval by the DRC if color of frame and handle match the color of the existing door or window frames and handles.

7.29 Sunshades

The use of exterior sunshades (also referred to as awnings or shades) over the balcony requires DRC approval. Sunshades must be compatible with the architectural character of the home in terms of color (solid colors are required), material and design. If approved, awnings and sunshades must be well-maintained. Frayed, torn or faded materials must be replaced in a timely manner. Non-fabric sunshades (such as aluminum, Fiberglass, bamboo or reed) are not permitted. Only manufactured sunshades are permitted; make-shift sunshades are not allowed.

- (a) Shades must run the entire length of the balcony or two of equal size mounted equal distance for the sides of the balcony.
- (b) Shades may be motorized or non-motorized.
- (c) Shades must be retracted when not in use.
- (d) Shades and mounting hardware must be rated for exterior use.
- (e) Shades must conform to the approved colors pursuant to **Exhibit C**.
- (f) Shades must be a minimum 80% ultraviolet (“UVC”) blocking. (80% is the minimum for knitted fabrics and polyvinyl chloride (“PVC”) fabrics.)
- (g) Shades must be solid color with no patterns, logos, or other distinguishing markings.
- (h) Shades must be inside mounted (prevents mounting bracket visibility outside of the unit, in other words, it cannot be mounted to the exterior of the unit)

7.30 Trampolines.

Trampolines DO NOT require submittal and approval by the DRC if the trampoline is less than ten feet (10') in height, located in the backyard and screened from street view behind a six foot (6') backyard wood perimeter fence (Examples 1, 2, or 3 on **Exhibit A**). Trampolines shall be setback a minimum of five feet (5') from property lines and are not allowed in front yards.

7.31 Trash/Garbage and Recycling Receptacles and Service.

When not placed outside for the purposes of trash pick-up, trash receptacles shall be screened from street view, behind wing fencing, or enclosed in the garage or accessory building. All trash receptacles and storage enclosures shall be planned as a part of the total fencing and landscape design and may be subject to the DRC’s approval.

The Trash/Garbage and Recycling service provider is Waste Connections, which has been contracted through the Town of Superior. This service is set-up and invoiced through your Town utility bill. Please see the Town of Superior website at <http://superiorcolorado.gov/services/trash-recycling> for more information and current prices, or contact the Superior Town Hall at (303) 499-3675.

7.32 Windows.

Window frames and appurtenances shall be approved by the DRC unless windows are replaced to match the original builder design. Window design shall be consistent with these Guidelines in size, proportions, detail and placement on the elevation.

EXHIBIT A
FENCING EXAMPLES

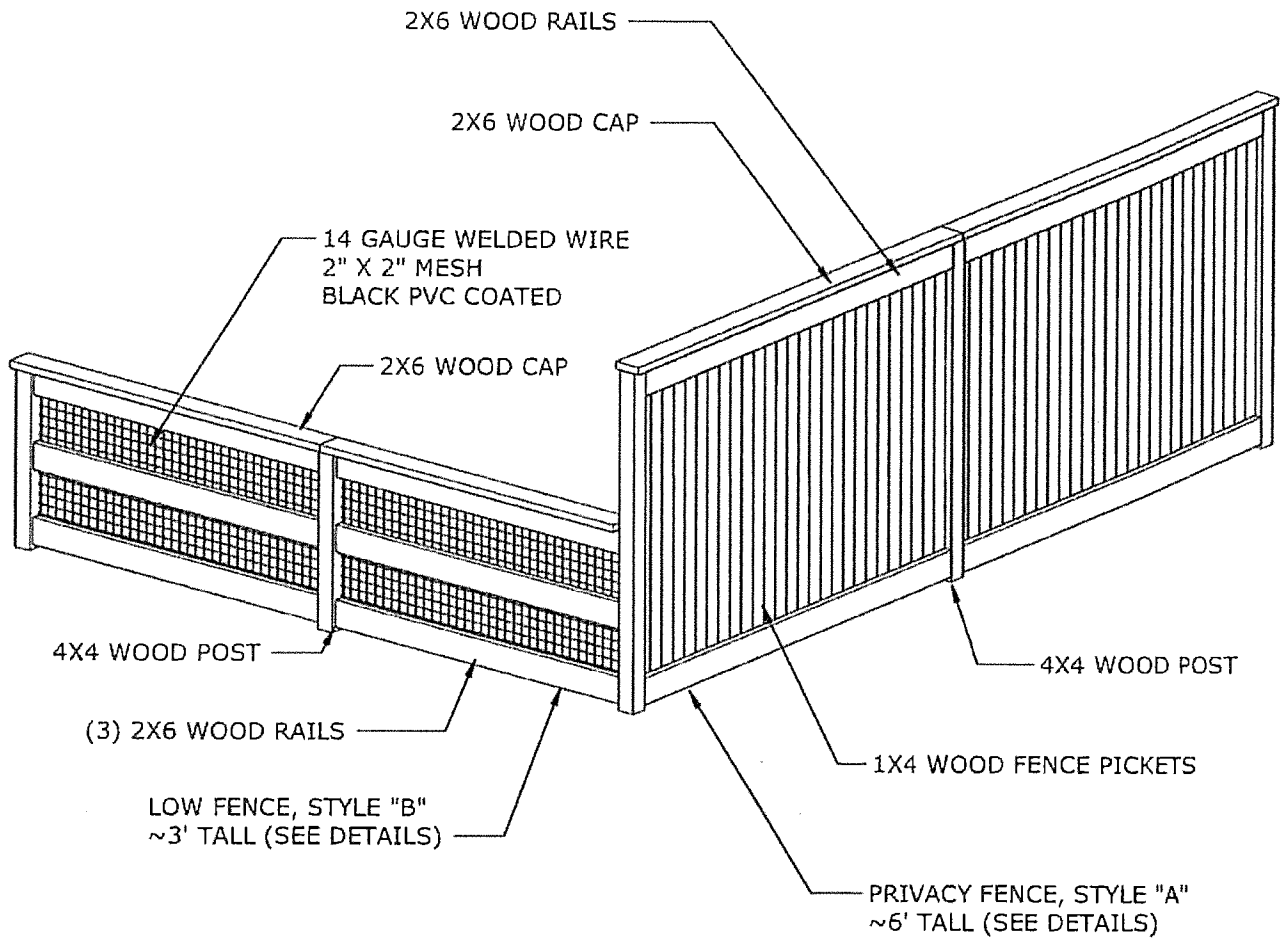

GENERAL NOTES:

1) ALL FENCE WOOD TO BE ROUGH MILLED CEDAR, AND FINISHED WITH EXTERIOR GRADE OIL-BASED TRANSPARENT WOOD STAIN, TWP 1501 "CEDARTONE" OR EQUAL. (OTHER STAIN COLORS MAY BE APPROVED BY THE DRC ON A CASE-BY-CASE BASIS.)

FENCE DIAGRAM (SEE ADDITIONAL DETAIL
ON FOLLOWING SHEETS)

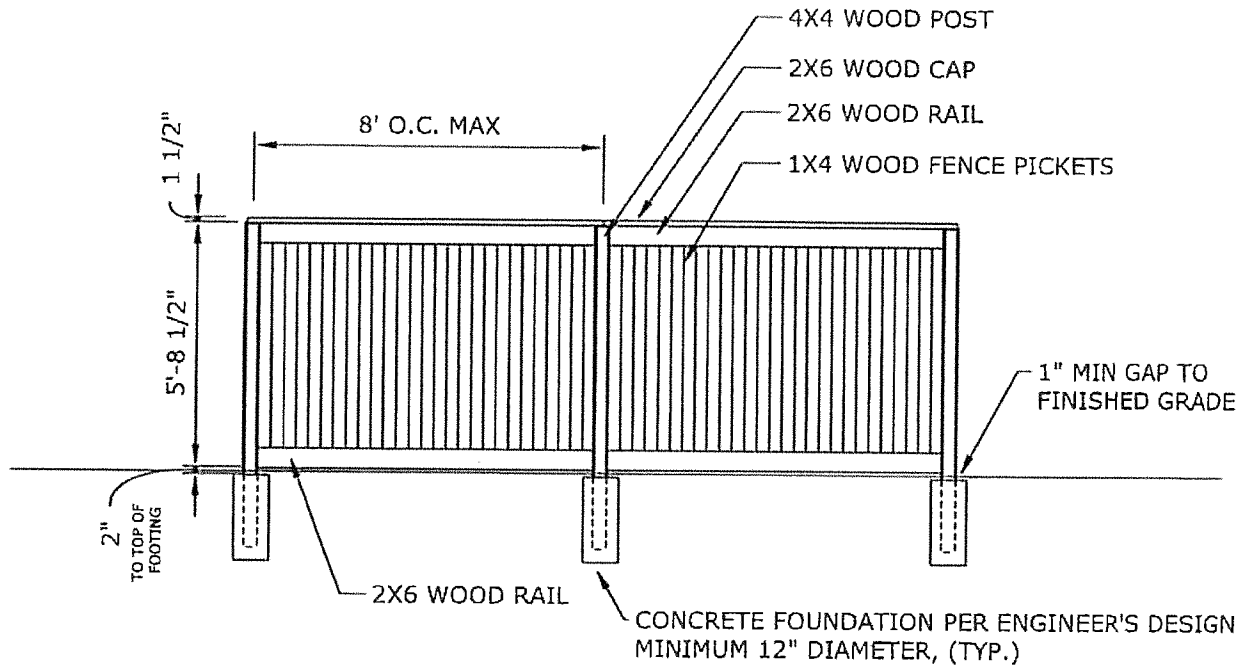

1 :: EXTERIOR ELEVATION (FACING PUBLIC)
 A scale 1/4" = 1'-0"

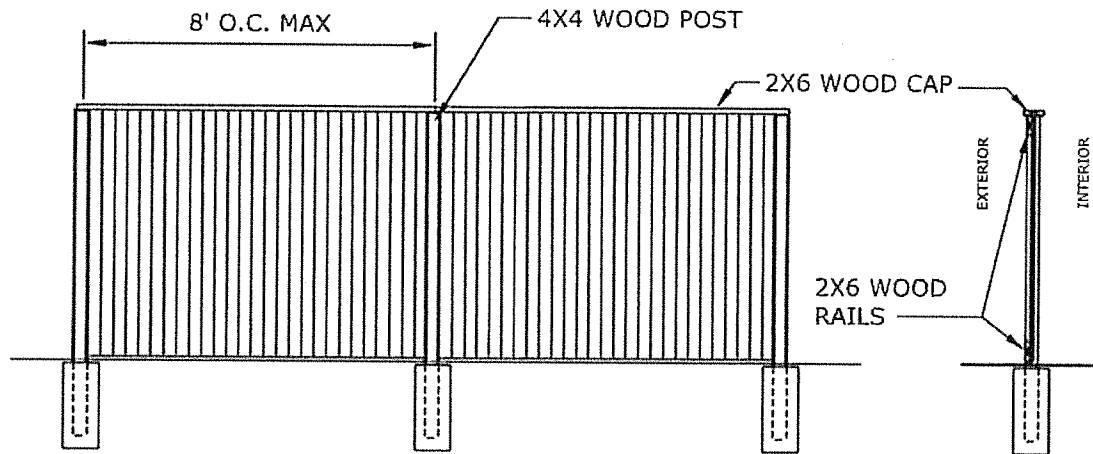

2 :: INTERIOR ELEVATION (FACING INSIDE PRIVATE LOT)
 A scale 1/4" = 1'-0"

3 SECTION VIEW
 A scale 1/4" = 1'-0"

FENCE TYPE A: 6' PRIVACY FENCE

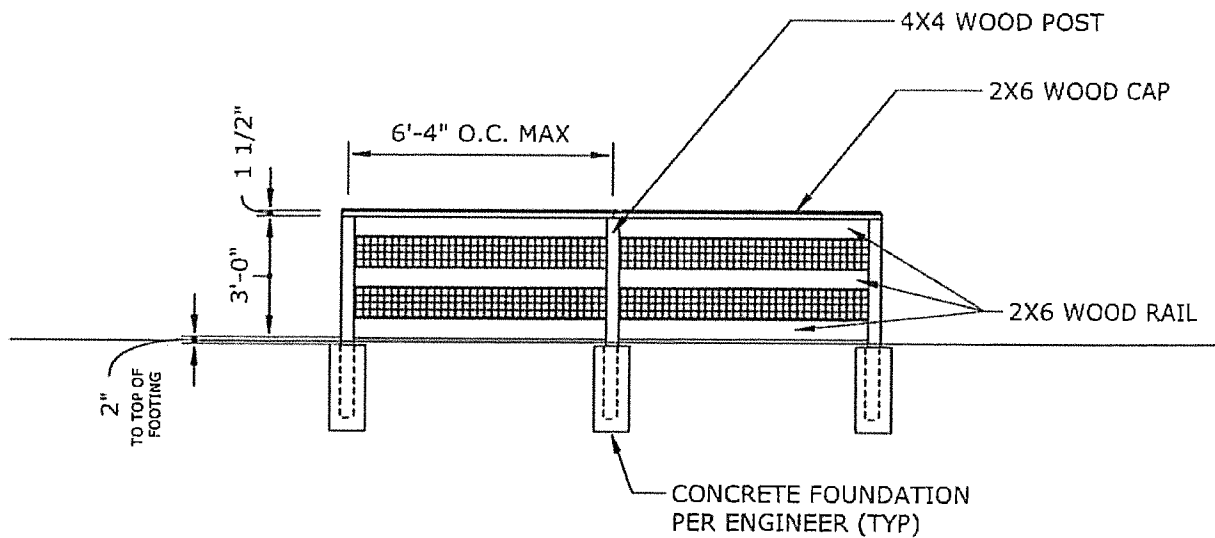

1	:: EXTERIOR ELEVATION (FACING PUBLIC)
B	Scale: 1/4" = 1'-0"

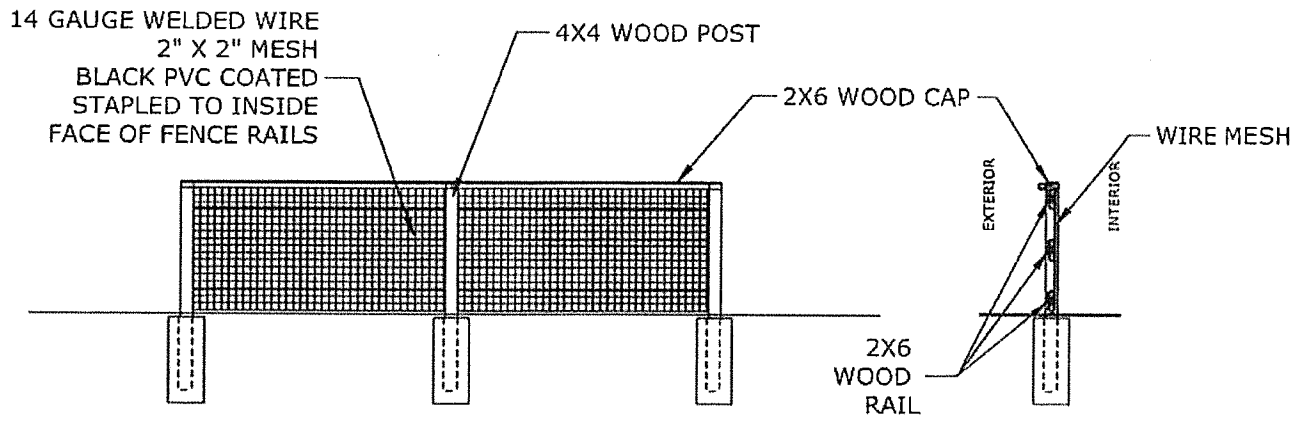

2	:: INTERIOR ELEVATION (FACING INTERIOR OF PRIVATE LOT)
B	Scale: 1/4" = 1'-0"

3	:: SECTION VIEW
B	Scale: 1/4" = 1'-0"

FENCE TYPE B: 3' VIEW FENCE

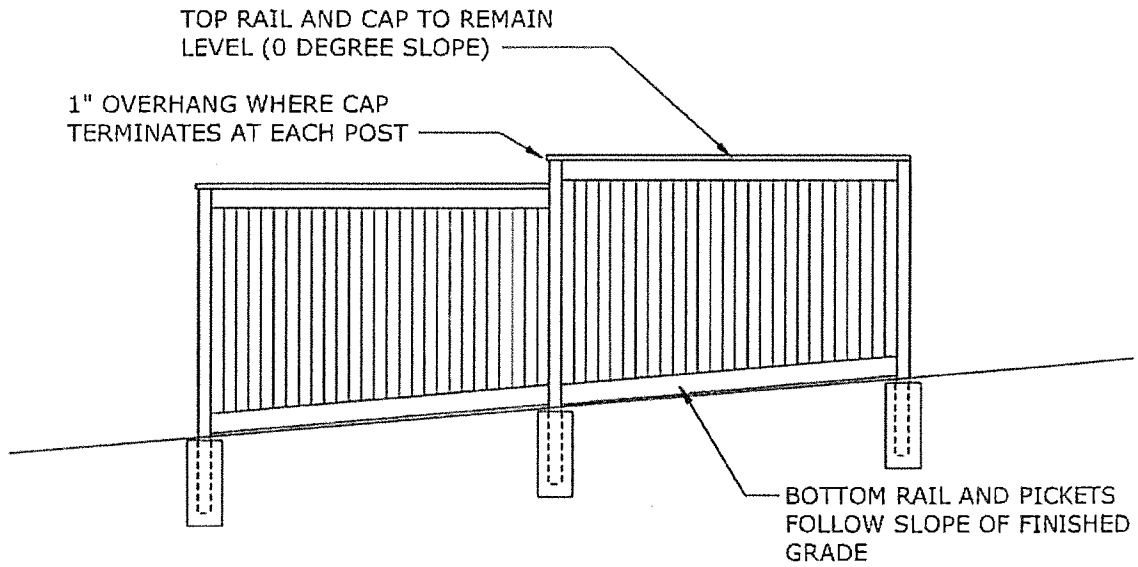

4	PRIVACY FENCE AT SLOPING LOT
B	

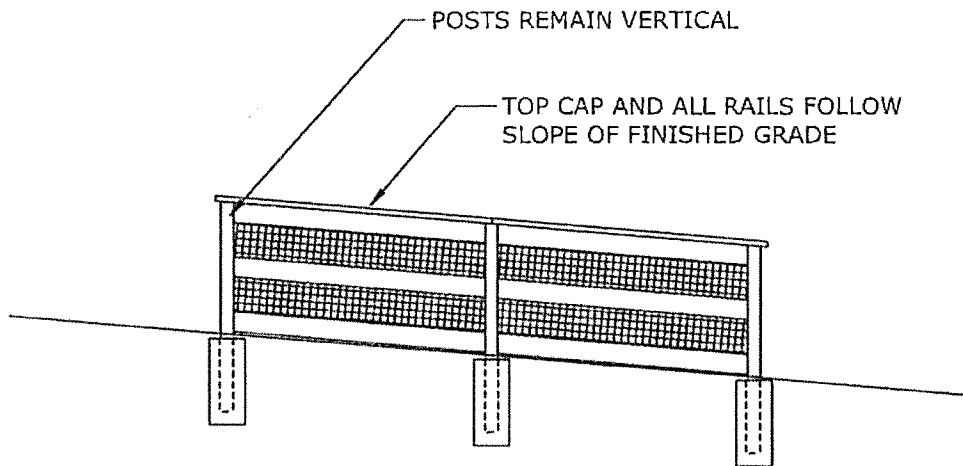

4	3' VIEW FENCE AT SLOPING LOT
B	

FENCE DESIGN FOR SLOPED AREAS

EXHIBIT B
PLANT LISTS



APPENDIX B - LANDSCAPE PLANT LIST

B.1 LANDSCAPE STANDARDS

All landscaping will be in compliance with or exceed these Design Guidelines. If landscape requirements are not specified in these Design Guidelines, the Town of Superior Municipal Code and Standard Specifications apply.



Minimum plant sizes should be used as follows:

Deciduous Street Canopy Trees - 2.5" minimum trunk caliper and first branch height at 6'-0"



Open Space / Parking Lot Canopy Trees - 2 1/2" minimum trunk caliper

Evergreen Trees - 10' minimum height

Ornamental Trees - 2" minimum trunk caliper



Evergreen and Deciduous Shrubs - 5 gallon container minimum

Ornamental Grasses - 5 gallon container minimum where available / 1 gallon for varieties not available in 5 gallon containers

Perennials/Groundcovers - 1 gallon container minimum



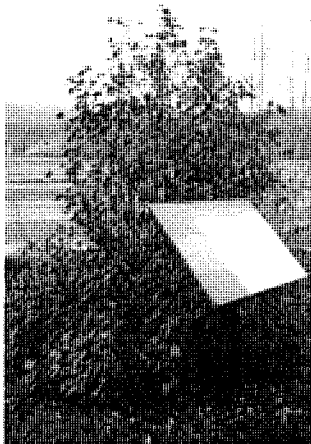

B.2 RECOMMENDED STREET TREES

Because of the importance of trees to the STC urban landscape, a list of trees that are suitable for the streetscape landscape has been developed. These trees were selected from the Town of Superior's Recommend Plant List and the 2010 Front Range Tree List Recommendation List, which is a collaborative effort by a committee of Colorado municipal arborist, nurserymen, landscape architects, and State Extension office staff.

Recommended Street Trees

Scientific Name	Common Name
<i>Acer Platanoides</i> varieties	
- 'Deborah'	Deborah Maple
- 'Emerald Lustre'	Emerald Lustre Maple
- 'Royal Red'	Royal Red Maple
<i>Carpinus caroliniana</i>	American Hornbeam
<i>Catalpa speciosa</i>	Western Catalpa
<i>Catalpa ovata</i>	Chinese Catalpa
<i>Celtis occidentalis</i>	Common Hackberry
<i>Gleditsia triacanthos</i> v. <i>inermis</i>	
- Imperial	Imperial Honeylocust
- Shademaster	Shademaster Honeylocust
- Skyline	Skyline Honeylocust
<i>Gymnocladus dioica</i>	Kentucky Coffeetree
<i>Pyrus calleryana</i> varieties	
- 'Canticleer'	Canticleer Pear
- 'Cleveland Select'	Cleveland Select Pear
- 'Redspire'	Redspire Pear
<i>Quercus alba</i> x <i>robur</i>	Crimson Spire Oak
<i>Quercus bicolor</i>	Swamp White Oak
<i>Quercus macrocarpa</i>	Bur Oak
<i>Quercus muehlenbergii</i>	Chinkapin Oak
<i>Quercus robur</i>	English Oak
<i>Quercus robur</i> 'Fastigiata'	Columnar English Oak
<i>Quercus shumardii</i>	Shumard Oak

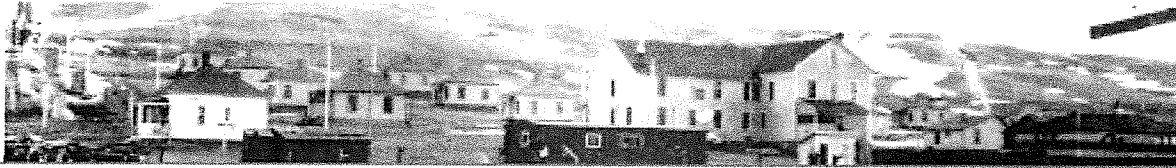

B.3 STREET TREES TO BE USED IN LIMITED NUMBERS

The following trees have typically performed well as street trees in Colorado, but should be used in limited quantities due to potential pest / disease problems or cultural limitations.

Ash Varieties: While Emerald Ash Bore (EAB) has not been found in Colorado, it is a serious problem in the Midwest. Ash should only be used in limited quantities as a precaution.

Scientific Name	Common Name
<i>Fraxinus americana</i> 'Autumn Purple'	Autumn Purple Ash
<i>Fraxinus pennsylvanica</i> 'Patmore'	Patmore Ash
<i>Fraxinus pennsylvanica</i> 'Marshalls'	Marshall Seedless Ash

Buckeye / Horsechestnut Varieties: Buckeye/ Horsechestnut (Ohio and Common) trees are excellent street trees that tolerate a wide variety of conditions and are very disease resistant. However, the fruit can be considered a nuisance in some urban settings.

Linden Varieties: Lindens are excellent street trees but should not be used in medians or along major arterial roads due to sensitivity to road salts. Recommended Lindens include:

Scientific Name	Common Name
<i>Tilia cordata</i> 'Greenspire'	Greenspire Linden
<i>Tilia x euchlora</i> 'Redmond'	Redmond Linden

Northern Red Oak (*Quercus rubra*): A fast growing, broad tree with good fall color, but can have problems with iron chlorosis in alkaline soils with a pH over 7.5.

An automatic irrigation system which employs drip ring emitters is required for all street trees.

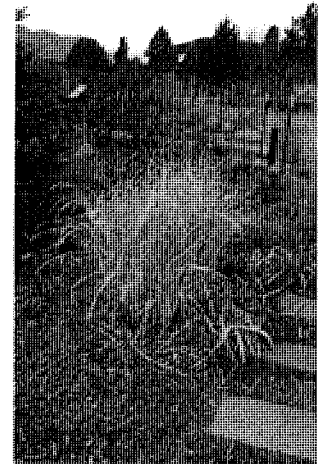



Structural backfill soils such as “CU Structural” (as defined by the Urban Horticulture Institute, Cornell University) shall be used for all street trees planted in sidewalks or planters smaller than 50 SF.

B.4 OTHER RECOMMENDED DECIDUOUS TREES

The following trees are suitable for open space areas, parking lot islands, buffers, or other non-street tree applications. Trees listed in 1.1 and 1.2 above are also suitable for these applications.

Other Recommended Deciduous Trees

Scientific Name	Common Name
<i>Acer grandidentatum</i>	Bigtooth Maple
<i>Acer ginnala</i> ‘Flame’	Flame Amur Maple
<i>Acer tataricum</i> ‘Hot Wings’	Hot Wings Maple
<i>Amelanchier canadensis</i>	Shadblow Serviceberry
<i>Amelanchier x grandiflora</i> ‘Autumn Brilliance’	Autumn Brilliance Serviceberry
<i>Cornus mas</i> ‘Golden Glory’	Golden Glory Cornelian Cherry
<i>Crataegus crus-galli</i>	Cockspur Hawthorn
<i>Crataegus crus-galli</i> var. <i>inermis</i>	Thornless Cockspur Hawthorn
<i>Crataegus phaenopyrum</i>	Washington Hawthorn
<i>Koelrueteria paniculata</i>	Golden Raintree
<i>Malus</i> sp. ‘Brandywine’	Brandywine Crabapple
<i>Malus</i> sp. ‘Indian Magic’	Indian Magic Crabapple
<i>Malus</i> sp. ‘Radiant’	Radiant Crabapple
<i>Malus</i> sp. ‘Spring Snow’	Spring Snow Crabapple
<i>Prunus cerasifera</i> ‘Newport’	Newport Purple Leaf Plum
<i>Prunus americana</i>	Native Plum
<i>Prunus maackii</i>	Amur Chokecherry
<i>Prunus virginiana</i> ‘Canada Red’	Canada Red Chokecherry
<i>Quercus gambelii</i>	Gambel Oak
<i>Syringa reticulata</i>	Japanese Tree Lilac

Note: Cottonwood trees may only be used in conjunction with a riparian corridor restoration plan for Coal Creek.

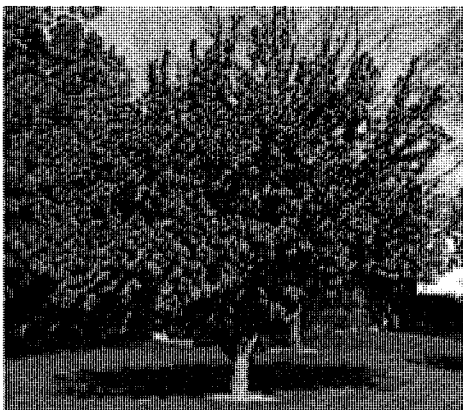
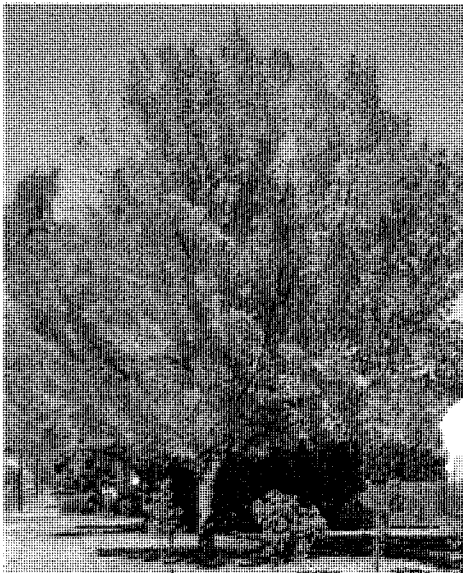



B.5 EVERGREEN TREES

Evergreen Trees

Scientific Name	Common Name
<i>Juniperus scopulorum</i>	Rocky Mountain Juniper
<i>Juniperus scopulorum</i> 'Wichita Blue'	Wichita Blue Upright Juniper
<i>Pinus edulis</i>	Pinyon Pine
<i>Pinus flexilis</i>	Limber Pine
<i>Pinus nigra</i>	Austrian Pine
<i>Pinus ponderosa</i>	Ponderosa Pine
<i>Pinus strobiformis</i>	Southwestern White Pine
<i>Picea pungens</i> 'Hoopsii'	Hoopsii Spruce
<i>Picea pungens glauca</i>	Colorado Blue Spruce



B.6 SHRUBS

Shrubs

Scientific Name	Common Name
<i>Amorpha canescens</i>	Leadplant
<i>Berberis thunbergii</i> 'Crimson Pygmy'	Crimson Pygmy Barberry
<i>Berberis thunbergii</i> 'Rose Glow'	Rose Glow Japanese Barberry
<i>Buddleia davidii</i> 'Pink Delight'	Pink Butterfly Bush
<i>Caryopteris x claud.</i> 'Dark Knight'	Dark Night Blue Mist Spirea
<i>Corneus sericea</i> 'Baileyi'	Bailey Redtwig Dogwood
<i>Cotoneaster lucidus</i>	Peking Cotoneaster
<i>Fallugia paradoxa</i>	Apache Plume
<i>Juniperus chinensis</i> 'Armstrong'	Armstrong Juniper
<i>Juniperus horizontalis</i> 'Icee Blue'	Icee Blue Juniper
<i>Juniperus sabina</i> 'Arcadia'	Arcadia Juniper
<i>Juniperus sabina</i> 'Scandia'	Scandia Juniper
<i>Pinus mugo</i> 'White Bud'	White Bud Mugo Pine
<i>Pinus mugo</i> 'Mops'	Miniature Mugo Pine
<i>Perovskia atriplicifolia</i>	Russian Sage
<i>Potentilla fruticosa</i> 'Gold Drop'	Gold Drop Potentilla
<i>Potentilla fruticosa</i> 'McKay's White'	McKay's White Potentilla
<i>Prunus besseyi</i>	Western Sandcherry

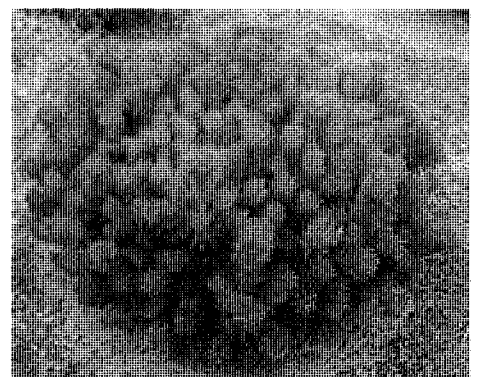
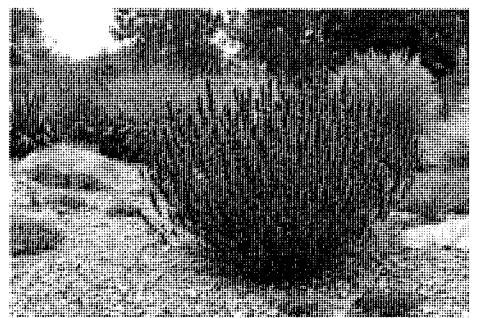

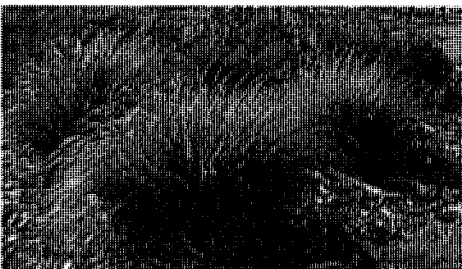
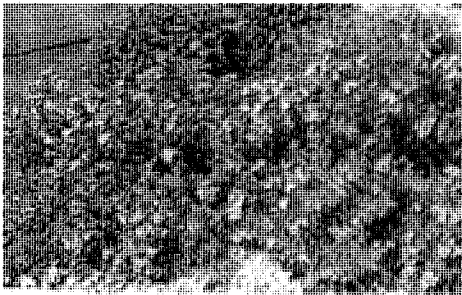

Shrubs (continued)

Scientific Name	Common Name
<i>Prunus besseyi</i> 'Pawnee Buttes'	Creeping Western Sandcherry
<i>Rosa</i> x 'Knock Out'	Knock Out Rose
<i>Rosa</i> x Meidiland Pink	Single Pink Shrub Rose
<i>Rosa</i> x Meidiland Scarlet	Meidiland Scarlet Rose
<i>Rosa</i> x Meidiland White	Double White Shrub
<i>Rose Rhus trilobata</i>	Three Leaf Sumac
<i>Ribes aureum</i>	Gold Current
<i>Rosa woodsii</i>	Woods Rose
<i>Spiraea japonica</i> 'Neon Flash'	Neon Flash Spirea
<i>Syringa vulgaris</i> 'Charles Joly'	Double Red French Lilac
<i>Viburnum dentatum</i> 'Blue Muffin'	Blue Muffin Arrowwood
<i>Viburnum opulus</i> 'Compactum'	Compact European Cranberry Bush

Ornamental Grasses

Scientific Name	Common Name
<i>Calamagrostis acutiflora</i> 'Overdam'	Overdam Feather Reed
<i>Festuca glauca</i> 'Elijah Blue'	Elijah Blue Fescue Grass
<i>Helictotrichon sempervirens</i>	Blue Avena Grass
<i>Miscanthus sinensis</i> 'Gracillimus'	Maiden Grass
<i>Miscanthus sinensis</i> 'Purpurescens'	Purple Flame Maiden Grass
<i>Panicum virgatum</i> 'Heavy Metal'	Heavy Metal Switch Grass
<i>Panicum virgatum</i> 'Prairie Sky'	Prairie Sky Switch Grass
<i>Pennisetum alopecuroides</i> 'Cassian'	Cassian Fountain Grass
<i>Pennisetum alopecuroides</i> 'Hameln'	Dwarf Fountain Grass



B.7 PERENNIALS AND GROUND COVER

Perennials and Ground Cover

Scientific Name	Common Name
<i>Achillea</i> 'Moonshine'	Moonshine Yarrow
<i>Coreopsis verticillata</i> 'Moonbeam'	Moonbeam Coreopsis
<i>Delosperma floribundum</i> 'Star Burst'	Star Burst Ice Plant
<i>Echinacea purpurea</i>	Purple Cone Flower
<i>Gaillardia x grandiflora</i> 'Goblins'	Goblin Gaillardia
<i>Kniphofia</i> 'Corallina'	Torch Lily or Red Hot
<i>Lavendula angustifolia</i> 'Hidcote'	Deep Blue Lavender
<i>Lupinus</i> 'Russel Hybrids'	Mixed Lupine
<i>Leucantheum x superbum</i>	Shasta Daisy
<i>Nepeta x faassenii</i> 'Six Hills Giant'	Catmint
<i>Rudbeckia fulgida</i> 'Goldstrum'	Black-eyed Susan
<i>Sedum</i> 'Autumn Joy'	Autumn Joy Stonecrop
<i>Sedum spurium</i> 'Dragon's Blood'	Dragon's Blood Stonecrop
<i>Salvia nemorosa</i> 'May Night'	May Night Salvia
<i>Saponaria ocyroides</i>	Rock Soapwort
<i>Zauschneria californica latifolia</i>	Hummingbird Flower

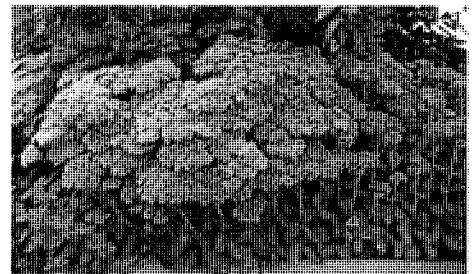
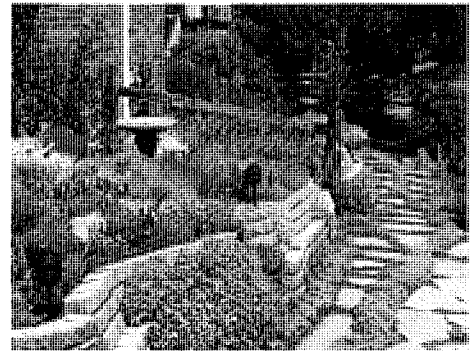

B.8 IRRIGATION

An automatic irrigation system is required in all planted areas and shrub beds. Low water use irrigation practices and grouping plants by water use requirements is strongly recommended.

B.9 TURF AND NATIVE GRASSES

To reduce water usage, Texas Bluegrass Hybrid variety (rather than Kentucky Bluegrass or Fescue turf grass sod) is encouraged for use (with approval by Town Staff) in the developed open space areas within the Town Center site. Soil prep and installation of sod shall be per the Town of Superior's Standard Specifications. An efficient automatic irrigation system is required in all sodded areas.



Native grass seed mixes are to be used in open space areas that are not programmed for active recreation or expected to receive heavy foot traffic. Approved native seed mixes are provided by the Town of Superior Parks and Recreation Department. Approved mixes include:

The Town's Standard Native Seed Mix
Rock Creek Native Irrigated Seed Mix
Rock Creek Native Dryland Seed Mix

An automatic irrigation system is required in all sodded and seeded areas, unless a non-irrigated dryland native seed mix is approved by the Town. Soil prep and installation of native seed mixes shall be per the Town of Superior's Standard Specifications.

B.10 PROHIBITED PLANTS

The following tree species are not allowed within STC: Russian Olive, Siberian Elms, Black Locust, Lombardy Poplar, Tamarix, Willow, Silver Maple and related hybrid tree species. Consult with the Town and Boulder County to make sure that nothing is planted that is on the prohibited noxious plant and weed list.

EXHIBIT C
EXTERIOR COLOR SCHEMES



APPENDIX C - ARCHITECTURAL COLOR/ MATERIALS PALETTE

C.1 ARCHITECTURAL COLOR PALETTE

A. The use of color to enliven building facades is an essential part of the design for STC. The following examples offer insight and suggestion as to the use of color within the project.

ACCENT COLOR PALETTE

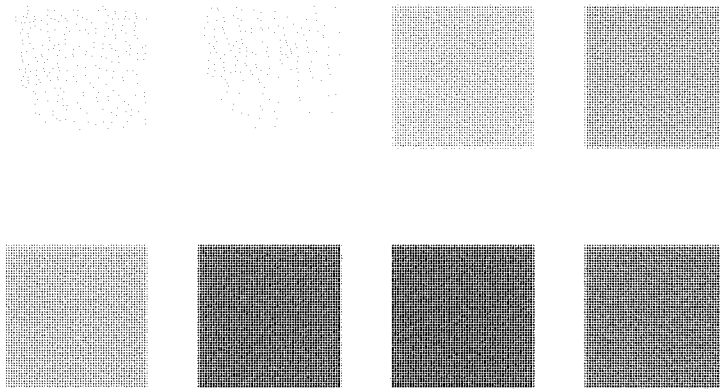

PRIMARY COLOR PALETTE

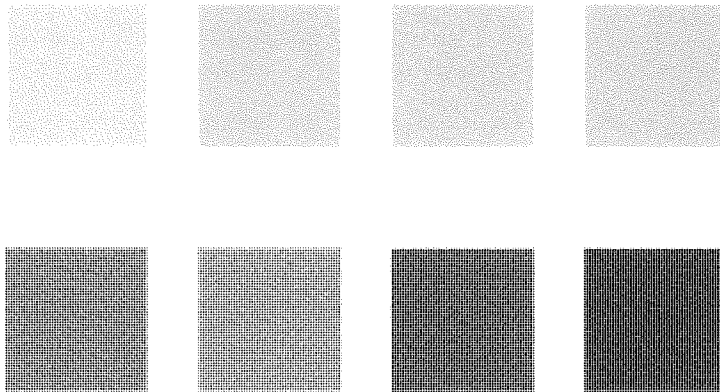

ROOF COLORS

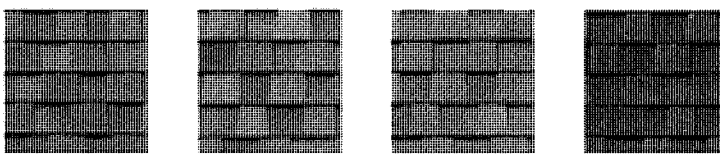



- B. The most saturated colors are reserved for accent elements (non wall elements). The entry features are an opportunity for the most of the wall colors to help call attention to the entries. Color changes are to be accompanied by a plane change or separated by a substantial reveal. The primary hues of the wall surfaces should relate to earth tones. Patterns should be mostly faux representations of historic or similar architectural elements. The use of color should augment, not diminish, the differences between the facades. The primary colors are the most consistent colors, acting as a common thread of infrastructural elements. Color palettes building to building should vary so that they preserve their individuality.
- C. Final building color palettes have not been determined; however, the palettes should be of similar tones, values and styles as the examples shown in Fig. C1. Final building colors will be submitted and reviewed during architectural review for each building.

Fig. C1

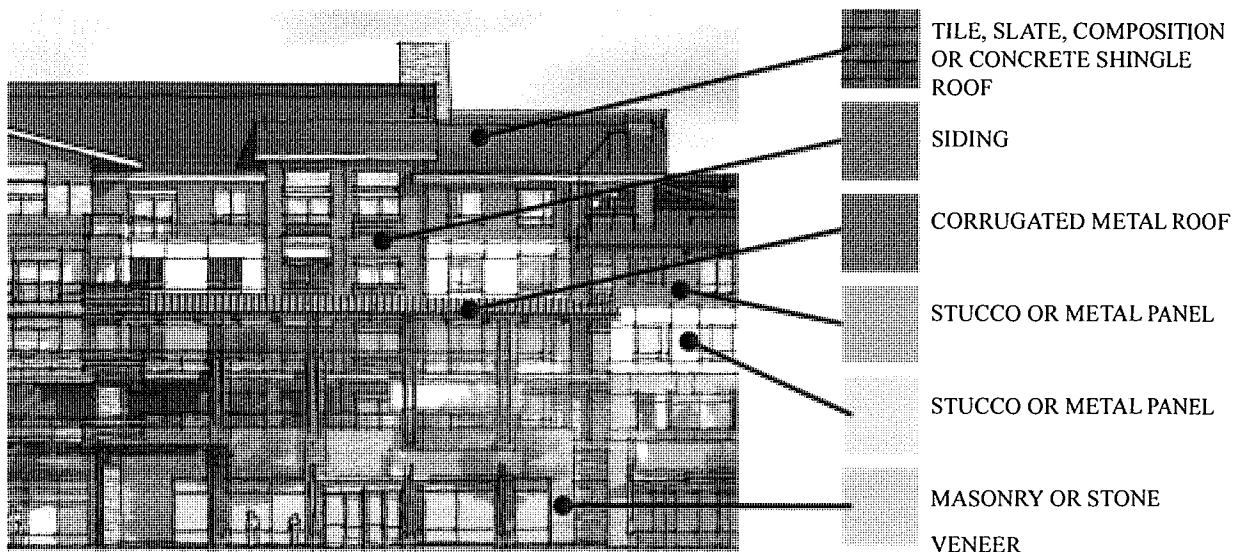

APPENDIX I

DESIGN REVIEW REQUEST INSTRUCTIONS

To make a request for design review, complete a request form and submit (with all back-up documents necessary) to:

STC Metropolitan District No. 2
141 Union Blvd., Suite 150
Lakewood, CO 80228
Phone Contact: 303-987-0835

SUBMISSION REQUIREMENTS

The Master Declaration of Covenants, Conditions, and Restrictions for Superior Town Center (Declaration) governs all Properties within Superior Town Center. A copy of the Declaration is available at any time from the District, and the Declaration is recorded in the real property records of Boulder County, Colorado. Each Owner should review and become familiar with the Declaration. Nothing in these Guidelines supersedes or alters the provisions or requirements of the Declaration and, if there is any conflict or inconsistency between these Guidelines and the Declaration, the Declaration controls.

Use of Property and Improvements must comply with the applicable building codes or other governmental requirements and regulations. Where the provisions of applicable federal, state, Boulder County and/or Town of Superior standards are more restrictive than the provisions of these Guidelines, such other more restrictive standards shall control. Unless specifically exempt, all Improvements must be approved by the DRC.

The DRC shall review each request for approval and make a decision within forty-five (45) days after payment of the submittal fee and the complete submission of plans, specifications and other materials and information, which the DRC may require in conjunction therewith. Any request for approval shall be deemed disapproved unless written approval is transmitted within sixty (60) days after the receipt by the DRC of all required fees and materials.

Submittal Fees shall be charged on the following schedule for each submittal:

<u>Fee Description</u>	<u>Fee Amount</u>
Landscape Review and/or Fence Review	\$50
Paint Color Change	\$50
Main Building Addition, Addition of Accessory Building, Shed, Deck, Patio, Site Plan, Footprint (including Driveway) Review	\$100
All other items	\$50

Landscaping - Include a plot plan showing in detail what you intend to accomplish. Be sure to show existing conditions as well as your proposed improvements. If you will be planting trees and shrubs, be sure to indicate the type and size on the plan.

If you will be installing rock or bark mulch in planting beds, be sure to specify the type, color and size. If you are using edging, be sure to specify the type of edging. If you are installing a retaining wall you must indicate how it will be constructed.

THIS IS EXTREMELY IMPORTANT - YOU MAY NOT ALTER THE DRAINAGE ON YOUR LOT.

Painting – if requesting a paint color other than the preapproved colors provided in **Exhibit C** of the Guidelines, submit paint samples and indicate the color in general terms of the houses on either side of yours (example: light beige with brown trim). Large samples help give a better impression of color than small samples.

Fencing – Be sure to show the location of the proposed fencing on a plot plan and describe the type of fence. Fences must be treated with clear waterproof stain or natural stain. The finished side of installed fencing should face away from your house.

Roofing – Submit manufacturer's sample or brochure showing the type and color of shingle you intend on using.

Patio Covers or Gazebos – You must submit a plot plan showing the proposed location in addition to elevations showing construction and exterior appearance. Also include exterior finish if other than natural.

DESIGN REVIEW REQUEST FORM

FOR OFFICE USE ONLY

STC Metropolitan District No. 2
141 Union Blvd., Suite 150
Lakewood, CO 80228
303-987-0835

Date Received _____
Crucial Date _____
Date Sent to Entity _____
Date Rcvd from Entity _____

HOMEOWNER'S NAME(S): _____

ADDRESS: _____

PHONE(S): _____

My request involves the following type of improvement(s):

- Landscaping
- Deck/Patio Slab
- Roofing
- Drive/Walk Addition
- Painting
- Patio Cover
- Shed/Room Addition
- Basketball Backboard
- Fencing
- Other:

Include a plot plan drawn to scale, and describe improvements, showing in detail what you intend to accomplish. Be sure to show existing conditions as well as your proposed improvements. Example: If you will be planting trees and shrubs, be sure to indicate the type and size on the plan.

I understand that I must receive approval from the DRC in order to proceed with installation of Improvements if Improvements vary from the Guidelines or are not specifically exempt. I understand that I may not alter the drainage on my lot. I understand that the DRC is not responsible for the safety of Improvements, whether structural or otherwise, or conformance with building codes or other governmental laws or regulations and that I may be required to obtain a building permit to complete the proposed Improvements. The DRC and the members thereof, as well as the District, the Board of Directors, or any representative of the DRC, shall not be liable for any loss, damage or injury arising out of or in any way connected with the performance of the DRC for any action, failure to act, approval, disapproval, or failure to approve or disapprove submittals, except to the extent the DRC or any individual DRC member acted willfully in bad faith. All work authorized by the DRC shall be completed within the time limits established specified below, but if not specified, not later than one year after the approval was granted. I further understand that following the completion of my approved Improvement, I must notify the DRC for final inspection of the Improvement and ultimate approval.

Date: _____

Homeowner's Signature: _____

DRC Action:

- Approved as submitted
- Approved subject to the following requirements:
- Disapproved for the following reasons:

All work to be completed no later than: _____

DRC Signature: _____ Date: _____

SUBMITTAL FEES

Submittal Fees shall be charged on the following schedule for each submittal:

<u>Fee Description</u>	<u>Fee Amount</u>
Landscape Review and/or Fence Review	\$50
Paint Color Change	\$50
Main Building Addition, Addition of Accessory Building, Shed, Deck, Patio, Site Plan, Footprint (including Driveway) Review	\$100
All other items	\$50

APPENDIX II
ANTENNA / SATELLITE DISH RULES AND REGULATIONS

Definition

Antenna / Satellite Dish – Any device for the receipt of broadcast services, including direct broadcast satellite (DBS), television broadcast, and multichannel multipoint distribution service (MMDS). A mast, cabling, supports, guy wires, conduits, wiring, fasteners, or other accessories necessary for the proper installation, maintenance, and use of a reception antenna shall be considered part of the antenna.

“Permitted Antennas” are defined as (a) an antenna which is less than one meter in diameter and is used to receive direct broadcast satellite service, including direct-to-home satellite services, or is used to receive or transmit fixed wireless signals via satellite; (b) an antenna which is less than one meter in diameter and is used to receive video programming services via multipoint distribution services, including multichannel multipoint distribution services, instruction television fixed services, and local multipoint distribution services or is used to receive or transmit fixed wireless signals other than via satellite; (c) an antenna which is designed to receive broadcast television broadcast signals; or (d) other antennas which are expressly permitted under applicable federal statutes or regulations. In the event a Permitted Antenna is no longer expressly permitted under applicable federal statutes or regulations, such antenna will no longer be a Permitted Antenna for purposes of this Section. Installation of Permitted Antennas shall not require DRC approval.

A. All Permitted Antennas shall be installed with emphasis on being as unobtrusive as possible to the community. To the extent that reception is not substantially degraded or costs unreasonably increased, all Permitted Antennas shall be screened from view from any street and nearby Lots to the maximum extent possible, and placement shall be made in the following order of preference:

1. Inside the structure of the house, not visible from the street.
2. Backyard (as defined in Section 5.01(f)) or side yard, behind and below the fence line.
3. Backyard or side yard, mounted on the house, in the least visible location below the roofline.
4. Side yard in front of wing fence, screened by and integrated into landscaping.
5. Back rooftop.
6. Front yard screened by and integrated into landscaping.

B. If more than one (1) location on the Lot allows for adequate reception without imposing unreasonable expense or delay, the order of preference described above shall be used, and the least visible site shall be selected.

C. Permitted Antennas shall not encroach upon common areas or any other Owner's property.

Installation of Antennae/Satellite Dishes

All installations must comply with all applicable building codes and other governmental regulations, and must be secured so they do not jeopardize the safety of residents or cause damage to adjacent properties. Any installation must strictly comply with FCC guidelines.

A. All Permitted Antennas shall be no larger, nor installed more visibly, than is necessary for reception of an acceptable signal.

B. Owners are responsible for all costs associated with the Permitted Antenna, including but not limited to costs to install, replace, repair, maintain, relocate, or remove the Permitted Antenna.

C. All cabling must be run internally when feasible, must be securely attached, and must be as inconspicuous as possible. Permitted Antennas, masts and any visible wiring may be required to be painted to match the color of the structure to which they are attached. The Owner should check with the installer/vendor for the appropriate type of paint.

D. All other antennas, not addressed above, are prohibited.

Maintenance and Repair

Maintenance and repair of antenna are the sole responsibility of the Owner and should be properly maintained so as not to pose a potential safety hazard to any person or property. Any repairs or maintenance should be dealt with quickly and properly by the Owner when required to avoid safety hazards. In the event the DRC determines that an antenna requires attention, the Owner shall be notified in writing that they must resolve the problem within the time frame determined by the DRC.

Liability

The Owner shall be responsible for any and all real or personal property, or for any injury resulting from the installation of the antenna and/or its use, including but not limited to damage to any real or personal property caused by, related to, or arising from the installation due to dislodgement, use, or maintenance of any antenna.

STC Metropolitan District No.2
May-19

	General	Debt	Capital	Totals
Disbursements	\$ 14,278.05	\$ -	\$ 6,244.09	\$ 20,522.14
		\$ -	\$ -	\$ -
Payroll	\$ 200.00	\$ -		\$ 200.00
Payroll Taxes District Portion	\$ 15.30	\$ -	\$ -	\$ 15.30
Total Disbursements from Checking Acct	\$14,493.35	\$0.00	\$6,244.09	\$20,737.44

Check No and Date	Payee	Invoice No	GL Account Title	GL Acct	Amount	Total
1373						
05/23/2019	Comcast	316389 5/19	Parking Structure	1-730	139.97	139.97
Total 1373:						139.97
1374						
05/23/2019	Doody Calls	22359	O&M - Maintenance	1-735	75.00	75.00
Total 1374:						75.00
1375						
05/23/2019	McGeady Becher P.C.	1190B 4/19	Legal	3-675	3,778.00	3,778.00
05/23/2019	McGeady Becher P.C.	1190B 4/19	Legal	1-675	5,312.10	5,312.10
Total 1375:						9,090.10
1376						
05/23/2019	Prairie Mountain Publishing	1595596	Legal	1-675	32.12	32.12
Total 1376:						32.12
1377						
05/23/2019	Ranger Engineering, LLC	1066	Engineering	3-784	1,275.00	1,275.00
Total 1377:						1,275.00
1378						
05/23/2019	Simmons & Wheeler, P.C.	24314	Accounting	1-612	630.24	630.24
05/23/2019	Simmons & Wheeler, P.C.	24314	Accounting	3-612	630.23	630.23
05/23/2019	Simmons & Wheeler, P.C.	24468	Accounting	1-612	560.86	560.86
05/23/2019	Simmons & Wheeler, P.C.	24468	Accounting	3-612	560.86	560.86
Total 1378:						2,382.19
1379						
05/23/2019	Special Dist Management Svcs	#1 APRIL 19	Management	1-680	132.50	132.50
05/23/2019	Special Dist Management Svcs	#2 APRIL 19	Management	1-680	2,574.95	2,574.95
05/23/2019	Special Dist Management Svcs	#2 APRIL 19	Accounting	1-612	644.00	644.00
05/23/2019	Special Dist Management Svcs	#2 APRIL 19	Covenant Control	1-682	1,054.50	1,054.50
05/23/2019	Special Dist Management Svcs	#3 APRIL 19	Management	1-680	168.00	168.00
Total 1379:						4,573.95
1380						
05/23/2019	Thyssenkrupp Elevator Corporati	3004554856	Parking Structure	1-730	165.00	165.00
Total 1380:						165.00
1381						
05/23/2019	Town of Superior	2289.5 5/19	Utilities	1-704	8.94	8.94
05/23/2019	Town of Superior	290.5 5/19	Utilities	1-704	13.37	13.37
05/23/2019	Town of Superior	411.5 5/19	Utilities	1-704	13.37	13.37
05/23/2019	Town of Superior	438.5 5/19	Utilities	1-704	8.94	8.94
Total 1381:						44.62
1382						
05/23/2019	Vargas Property Services, Inc.	28481	O&M - Maintenance	1-735	2,115.17	2,115.17

Check No and Date	Payee	Invoice No	GL Account Title	GL Acct	Amount	Total
Total 1382:						<u>2,115.17</u>
1383						
05/23/2019	Xcel Energy	636013968	Utilities	1-704	99.32	99.32
05/23/2019	Xcel Energy	636019742	Utilities	1-704	103.02	103.02
05/23/2019	Xcel Energy	636020721	Utilities	1-704	87.78	87.78
05/23/2019	Xcel Energy	636036281	Utilities	1-704	124.81	124.81
05/23/2019	Xcel Energy	636037454	Utilities	1-704	42.52	42.52
05/23/2019	Xcel Energy	636055546	Utilities	1-704	171.57	171.57
Total 1383:						<u>629.02</u>
Grand Totals:						<u><u>20,522.14</u></u>

<u>Check Issue Date</u>	<u>Check Number</u>	<u>Payee</u>	<u>Amount</u>
05/23/2019	9122	Brzostowicz, James	
05/23/2019	9123	Hulsebus, Angie	92.35
Grand Totals:			
	<u>2</u>		<u>92.35</u>

STC Metropolitan District #2
Financial Statements

April 30, 2019

ACCOUNTANT'S COMPILATION REPORT

Board of Directors
STC Metropolitan District #2

Management is responsible for the accompanying financial statements of each major fund of STC Metropolitan District #2, as of and for the period ended April 30, 2019, which are comprised of the Balance Sheet and the related Statement of Revenues, Expenditures and Changes in Fund Balance – Budget and Actual – Governmental Funds and account groups for the four months then ended in accordance with accounting principles generally accepted in the United States of America. We have performed a compilation engagement in accordance with the Statements on Standards for Accounting and Review Services promulgated by the Accounting and Review Services Committee of the AICPA. We did not audit or review the financial statements nor were we required to perform any procedures to verify the accuracy or completeness of the information provided by management. Accordingly, we do not express an opinion, a conclusion, nor provide any form of assurance on these financial statements.

Management has elected to omit the Statement of Net Position, Statement of Activities, Management Discussion and Analysis and all of the disclosures required by accounting principles generally accepted in the United States of America. If the omitted disclosures were included in the financial statements, they might influence the user's conclusions about the District's financial position and results of operations. Accordingly, the financial statements are not designed for those who are not informed about such matters.

We are not independent with respect to STC Metropolitan District #2 because we performed certain accounting services that impaired our independence.

Simmons & Wheeler P.C.

May 23, 2019
Englewood, Colorado

STC Metropolitan District No 2
Balance Sheet - Governmental Funds and Account Groups
April 30, 2019

See Accountant's Compilation Report

	<u>General Fund</u>	<u>Debt Service Fund</u>	<u>Capital Projects Fund</u>	<u>Account Groups</u>	<u>Total All Funds</u>
Assets					
Current assets					
Cash in checking	\$ 196,148	\$ 9,348	\$ 15,255	\$ -	\$ 220,751
UMB PIF Supp Interest	-	13,508	-	-	13,508
UMB Non-PIF Supp Interest	-	343	-	-	343
UMB Non-PIF Surplus	-	1,357,745	-	-	1,357,745
UMB Non-PIF Supp Principal	-	1,299,181	212	-	1,299,393
UMB PIF Supp Res Account	-	1,604,274	-	-	1,604,274
Prepaid Expenses	-	-	-	-	-
Developer Receivable	-	-	-	-	-
SURA Taxes Receivable	-	-	-	-	-
Taxes receivable	87	306	-	-	393
MOB Receivable	315	-	-	-	315
Due from District No. 1	27	134	-	-	161
Due from District No 3	6	11	-	-	17
Due to/from Other funds	-	-	-	-	-
	<u>196,583</u>	<u>4,284,850</u>	<u>15,467</u>	<u>-</u>	<u>4,496,900</u>
Other assets					
Amount available in debt service fund	-	-	-	4,284,850	4,284,850
Amount to be provided for retirement of debt	-	-	-	41,537,081	41,537,081
	<u>-</u>	<u>-</u>	<u>-</u>	<u>45,821,931</u>	<u>45,821,931</u>
	<u>\$ 196,583</u>	<u>\$ 4,284,850</u>	<u>\$ 15,467</u>	<u>\$ 45,821,931</u>	<u>\$ 50,318,831</u>
Liabilities and Equity					
Current liabilities					
Accounts payable	13,500	-	5,683	-	19,183
Retainage Payable	-	-	9,286	-	9,286
Payroll Taxes Payable	\$ 122	\$ -	\$ -	\$ -	\$ 122
	<u>13,622</u>	<u>-</u>	<u>14,969</u>	<u>-</u>	<u>28,591</u>
Bonds Payable - Series 2015A	-	-	-	15,795,000	15,795,000
Bonds Payable - Series 2015B	-	-	-	7,000,000	7,000,000
Unpaid interest Series 2015B	-	-	-	1,013,553	1,013,553
Developer Note - O&M	-	-	-	791,178	791,178
Accrued Int Dev Note - O&M	-	-	-	131,658	131,658
Developer Note - Capital	-	-	-	19,547,460	19,547,460
Accrued Int Dev Note - Capital	-	-	-	2,017,945	2,017,945
Bond Discount	-	-	-	(474,863)	(474,863)
Total liabilities	<u>13,622</u>	<u>-</u>	<u>14,969</u>	<u>45,821,931</u>	<u>45,850,522</u>
Fund Equity					
Investment in capital improvements	-	-	-	-	-
Fund balance (deficit)	173,435	4,284,850	498	-	4,458,783
Emergency reserves	9,526	-	-	-	9,526
	<u>182,961</u>	<u>4,284,850</u>	<u>498</u>	<u>-</u>	<u>4,468,309</u>
	<u>\$ 196,583</u>	<u>\$ 4,284,850</u>	<u>\$ 15,467</u>	<u>\$ 45,821,931</u>	<u>\$ 50,318,831</u>

STC Metropolitan District No 2
Statement of Revenues, Expenditures and Changes in Fund Balance
Budget and Actual
For the Four Months Ended April 30, 2019
General Fund

See Accountant's Compilation Report

	<u>Annual Budget</u>	<u>Actual</u>	Variance Favorable (Unfavorable)
Revenues			
Property taxes	\$ 176	\$ 20	\$ (156)
Specific ownership taxes	8,200	314	(7,886)
SURA Property Tax Increment	102,495	37,336	(65,159)
Parking Garage Cost Share	22,000	3,001	(18,999)
Developer Advance	10,000	167,212	157,212
Miscellaneous/Interest Income	-	1,581	1,581
Transfer from District 1	40,007	22,072	(17,935)
Transfer from District 3	4,835	2,085	(2,750)
	<u>187,713</u>	<u>233,621</u>	<u>45,908</u>
Expenditures			
Accounting	25,000	5,336	19,664
Audit	11,000	-	11,000
Directors' Fees	5,000	800	4,200
Insurance/SDA Dues	16,000	24,676	(8,676)
Election	-	-	-
Legal	40,000	14,762	25,238
Management	50,000	18,621	31,379
Miscellaneous	1,000	98	902
Aweida Inclusion Expense	-	143	(143)
O&M - Covenant Control	18,000	4,199	13,801
O&M - Field Services	6,500	-	6,500
O&M - Landscaping	45,000	13,631	31,369
O&M - Equipment	1,500	-	1,500
O&M - Utilities	5,000	1,902	3,098
O&M - Monumentation	-	-	-
O&M - Roads & Sidewalks	40,000	38,401	1,599
O&M - Parking Garage	44,000	1,675	42,325
O&M - Mailboxes	2,000	-	2,000
O&M - Reserve	3,224	-	3,224
Treasurer's Fees	3	1	2
Payroll Taxes	300	61	239
Utilities	4,000	1,267	2,733
Emergency reserve	9,526	-	9,526
	<u>327,053</u>	<u>125,573</u>	<u>201,480</u>
Excess (deficiency) of revenues over expenditures	(139,340)	108,048	247,388
Fund balance - beginning	<u>139,340</u>	<u>74,913</u>	<u>(64,427)</u>
Fund balance - ending	<u>\$ -</u>	<u>\$ 182,961</u>	<u>\$ 182,961</u>

STC Metropolitan District No 2
Statement of Revenues, Expenditures and Changes in Fund Balance
Budget and Actual
For the Four Months Ended April 30, 2019
Debt Service Fund

See Accountant's Compilation Report

	Amended <u>Budget</u>	<u>Actual</u>	Variance Favorable (Unfavorable)
Revenues			
Property Taxes	\$ 689	\$ 69	\$ (620)
SURA Property Tax Increment	1,527,446	840,265	(687,181)
Specific Ownership taxes	4,577	1,098	(3,479)
PIF-Property Tax	-	-	-
Interest income	18,000	23,300	5,300
Transfer from Capital Projects	-	-	-
Transfer from STCMD No. 1	133,244	88,901	(44,343)
Transfer from STCMD No. 3	<u>10,107</u>	<u>4,271</u>	<u>(5,836)</u>
	<u>1,694,063</u>	<u>957,904</u>	<u>(736,159)</u>
Expenditures			
Bond interest - 2015A	1,023,300	-	1,023,300
Bond principal - 2015A	1,260,000	-	1,260,000
Miscellaneous Expense	500	-	500
Treasurer's Fees	28,610	5	28,605
Trustee / paying agent fees	<u>4,000</u>	<u>4,000</u>	<u>-</u>
	<u>2,316,410</u>	<u>4,005</u>	<u>2,312,405</u>
Excess (deficiency) of revenues over expenditures	(622,347)	953,899	1,576,246
Fund balance - beginning	<u>2,909,609</u>	<u>3,330,951</u>	<u>421,342</u>
Fund balance - ending	<u>\$ 2,287,262</u>	<u>\$ 4,284,850</u>	<u>\$ 1,997,588</u>

STC Metropolitan District No 2
Statement of Revenues, Expenditures and Changes in Fund Balance
Budget and Actual
For the Four Months Ended April 30, 2019
Capital Projects Fund

See Accountant's Compilation Report

	<u>Annual Budget</u>	<u>Actual</u>	Variance Favorable (Unfavorable)
Revenues			
Developer Advance	5,000,000	1,257,975	(3,742,025)
Interest	<u>1,000</u>	<u>(2)</u>	<u>(1,002)</u>
	<u>5,001,000</u>	<u>1,257,973</u>	<u>(3,743,027)</u>
Expenditures			
Accounting	5,000	2,186	2,814
Legal	55,000	16,227	38,773
Management	2,500	-	2,500
Construction Expenses	5,000,000	1,084,679	3,915,321
Engineering	200,000	132,764	67,236
Miscellaneous	<u>1,000</u>	<u>-</u>	<u>1,000</u>
	<u>5,263,500</u>	<u>1,235,856</u>	<u>4,027,644</u>
Excess (deficiency) of revenues over expenditures	(262,500)	22,117	284,617
Fund balance - beginning	<u>279,612</u>	<u>(21,619)</u>	<u>(301,231)</u>
Fund balance (deficit) - ending	<u>\$ 17,112</u>	<u>\$ 498</u>	<u>\$ (16,614)</u>

**STC Metropolitan District
Community Management Report
June 5, 2019**

Architectural Reviews

No forms pending.

Inspections

Inspection was conducted on May 14.

Compliance Update

There are very few violations; even trash cans are being put away!

The meeting with the homeowners on May 15th was very useful; the homeowners had a lot of great questions and it was instrumental in opening a positive line of communication.

Updates from May Meeting:

1. **Parking Garage Insurance-** The premium for insurance was added on the first invoice that was sent for the MOB.
2. **Drainage on Sidewalk-** 2322 Marigold Pl- The contractor has a plan to fix it; we are in the process of working out if it is a warranty repair.
3. **Teams working out in alleys-** We sent an e-mail to The Sports Stable manager asking that they communicate the issue with their teams. We also let the homeowners know to contact the Stable when they see if.
4. **Crumbling Driveway (Homeowner complaint)-** As no ice melt was used this winter, this is a warranty item. We let the homeowner know that and they are contacting the builder.
5. **Posting Board-** The best option is to install on the concrete by the pedestrian exit. Ideally, a posting board put in the landscaping would be best but we don't own that area.
6. **Dog Stations-**The stations will be installed by Vargas. They are in their office and should be installed by the meeting or soon after; we will be meeting them the week of May 28th to confirm locations.



**STC METROPOLITAN DISTRICT NO. 2
ENGINEER'S REPORT and CERTIFICATION #48**

PREPARED FOR:

STC Metropolitan District No. 2
141 Union Blvd
Lakewood, CO 80228

PREPARED BY:

Ranger Engineering, LLC
2590 Cody Ct.
Lakewood, CO 80215

DATE PREPARED:

May 24, 2019

TABLE OF CONTENTS

Engineer’s Report

Introduction	3
Public Improvements as Authorized by the Service Plan	5
Scope of Certification	5
General Methodology	5
Phase I – Authorization to Proceed and Document Gathering	5
Phase II – Site Visits and Meetings.....	6
Phase III – Review of Documentation	6
Phase IV – Verification of Construction Quantities	6
Phase V – Verification of Construction Unit Costs and Indirect Costs.....	6
Phase VI – Verification of Payment for Public Costs.....	6
Phase VII – Determination of Costs Eligible for Reimbursement	7

Engineer’s Certification

Engineer’s Certification	9
--------------------------------	---

Appendices

Appendix A – Documents Reviewed	10
---------------------------------------	----

Tables

Table I Costs Certified to Date	3
Table II Cost Summary	12
Table III Construction Costs Summary by Category	13
Table IV Soft and Indirect Costs Summary by Category	14
Table V District Funded Costs Summary by Category	15
Table VI System Development Fee Costs Summary.....	16
Table VII Construction Costs Detail	17
Table VIII Soft and Indirect Costs Detail	18
Table IX District Funded Costs Detail	19
Table X System Development Fee Costs	20

ENGINEER’S REPORT

Introduction

Ranger Engineering, LLC. (“Ranger”) was retained by STC Metropolitan District No. 2 (“District”) as an Independent Consulting Engineer to certify costs associated with constructed Public Improvements associated with the District. Per the Cost Sharing Agreement between the Superior Urban Renewal Authority (“SURA”) representing the Town of Superior (“Town”), RC Superior LLC (“Developer”), and the District, a portion of the costs are eligible to be reimbursed by the Town of Superior. It should be noted that personnel from Ranger were formerly part of Tamarack Consulting, LLC and Manhard Consulting, Ltd., both of which have been engaged by the District to certify costs related to the Public Improvements.

The District is located within the Town of Superior, Colorado. The development area is approximately 91 acres. This certification considers soft & indirect and construction costs.

The attached Engineer’s Certification states that the Independent Consulting Engineer finds and determines that the constructed value of the Public Improvements considered in this Engineer’s Report, including both soft and hard costs from approximately March 2019 to April 2019, are valued at **\$2,993,588.74** for the District, and **\$907,423.74** for the Town. Table I summarizes costs certified to date.

Table I – Cost Certified to Date				
Cert No.	Date	Total Costs Paid	Total District Eligible Costs	Total Town Eligible Costs
1	17-Feb-15	\$4,643,001.98	\$3,207,467.82	\$3,207,467.82
2	16-Jul-15	\$701,094.68	\$322,489.80	\$322,489.80
3	14-Aug-15	\$959,075.78	\$489,247.48	\$489,247.48
4	17-Sep-15	\$1,219,271.89	\$683,402.69	\$683,402.69
5	19-Oct-15	\$2,119,386.67	\$1,446,709.01	\$1,446,709.01
6	17-Nov-15	\$1,231,778.40	\$984,437.64	\$984,437.64
7	21-Dec-15	\$1,017,615.94	\$910,069.14	\$910,069.14
8	19-Jan-16	\$739,528.78	\$563,708.01	\$563,708.01
9	25-Feb-16	\$495,715.12	\$461,463.79	\$461,463.79
10	17-Mar-16	\$332,878.20	\$300,162.73	\$300,162.73
11	18-Apr-16	\$198,444.34	\$173,549.33	\$173,549.33
12	20-May-16	\$398,396.63	\$334,538.75	\$334,538.75
13	20-Jun-16	\$772,592.31	\$627,210.02	\$627,210.02
14	27-Jul-16	\$647,191.62	\$622,677.30	\$622,677.30
15	15-Aug-16	\$414,015.43	\$374,344.41	\$374,344.41
16	23-Sep-16	\$674,802.27	\$652,819.56	\$652,819.56
17	20-Oct-16	\$1,127,902.22	\$991,366.52	\$991,366.52
18	23-Nov-16	\$1,358,809.86	\$1,176,715.72	\$1,176,715.72
19	19-Dec-16	\$813,631.42	\$661,258.25	\$661,258.25
20	25-Jan-17	\$834,276.57	\$757,405.36	\$757,405.36

21	23-Feb-17	\$784,846.38	\$694,206.67	\$694,206.67
22	17-Mar-17	\$663,385.40	\$571,156.39	\$571,156.39
23	20-Apr-17	\$912,437.74	\$894,668.66	\$894,668.66
24	17-May-17	\$488,722.33	\$477,391.96	\$477,391.96
25	29-Jun-17	\$2,648,255.90	\$842,092.22	\$842,092.22
26	3-Aug-17	\$476,010.18	\$425,687.34	\$425,687.34
27	17-Aug-17	\$995,465.07	\$781,719.74	\$781,719.74
28	21-Sep-17	\$2,202,490.66	\$1,813,800.55	\$1,813,800.55
29	11-Nov-17	\$2,372,127.66	\$2,363,679.49	\$2,363,679.49
30	22-Nov-17	\$1,914,639.28	\$1,929,475.33	\$1,711,298.63
31	19-Dec-17	\$1,731,761.49	\$1,561,854.08	\$1,440,391.55
32	16-Feb-18	\$582,701.05	\$559,378.98	\$461,363.52
33	10-Apr-18	\$932,657.82	\$858,000.53	\$690,670.88
34	10-Apr-18	\$670,283.35	\$623,505.43	\$519,950.65
35	18-Jun-18	\$1,053,420.34	\$695,052.19	\$469,031.50
36	13-Jul-18	\$1,315,446.78	\$998,428.76	\$805,440.44
37	31-Jul-18	\$1,097,722.72	\$1,019,716.46	\$910,204.30
38	23-Aug-18	\$998,452.43	\$790,429.34	\$757,296.58
39	26-Sep-18	\$1,181,782.21	\$1,008,881.48	\$851,219.77
40	10-Oct-18	\$506,528.48	\$438,293.56	\$395,834.23
41	06-Dec-18	\$883,785.69	\$837,473.61	\$444,364.63
42	03-Jan-19	\$223,714.21	\$179,926.82	\$137,852.65
43	09-Jan-19	\$266,323.20	\$198,080.87	\$180,809.72
44	24-Jan-19	\$105,648.98	\$82,117.55	\$82,117.55
45	21-Feb-19	\$291,779.76	\$259,508.79	\$259,508.79
46	20-Mar-19	\$325,500.49	\$212,355.06	\$212,355.06
47	25-Apr-19	\$315,703.35	\$288,250.21	\$288,250.21
48	24-May-19	\$3,914,693.66	\$2,993,588.74	\$907,423.74

TOTALS **\$50,555,696.72** **\$40,139,764.14** **\$36,130,830.73**

Table II summarizes the cost breakdown of the construction, soft and indirect, district funded costs, and system development fees. Tables III, IV, V, and VI provide category breakdowns of construction, soft and indirect, district funded costs, and system development fees reviewed for this certification. Table VII provides a detailed breakdown of the eligible hard costs per the Service Plan categories and the SURA categories. Table VIII provides a detailed breakdown of the eligible soft costs per the Service Plan categories and the SURA categories. Table IX provides a detailed breakdown of district funded costs per the Service Plan categories and the SURA categories. Table X provides a detailed breakdown of system develop fee costs per the Service Plan categories and the SURA categories.

Public Improvements as Authorized by the Service Plan

Ranger reviewed the Service Plan associated with Superior Town Center Metropolitan District No. 2 ("Service Plan"); dated May 13, 2013.

Section I-A of the Service Plan states:

It is intended that the District will provide a part or all of the Public Improvements for the use and benefit of the anticipated inhabitants and taxpayers of the District. The primary purpose of the District will be to finance the construction of these public improvements.

Section V-A of the Service Plan States:

The District shall have the power and authority to provide the Public Improvements and related operations and maintenance services within and beyond the District Boundaries as such power and authority is described in the Special District Act, and other applicable statutes, common law and the Constitution, subject to the limitations set forth herein.

Section V-A.8 limits debt issuance to \$145,000,000. Exhibit C-2 maps depict the Inclusion Area of Public Improvements at the time the Service Plan was approved. Ranger has determined that the constructed improvements and associated soft and indirect construction costs ("Public Improvements") under consideration in this report and certification for reimbursement by the District are indeed authorized by the Service Plan.

Scope of Certification

The Cost Sharing Agreement has identified cost categories eligible for reimbursement. The cost categories reviewed for this report include earthwork, storm sewer, sanitary sewer, domestic water, and mob & temporary conditions. For a breakdown of district eligible costs, refer to Tables II - VIII.

General Methodology

Ranger employed a phased approach toward the preparation of this Engineer's Report and Certification of Public Costs ("Engineer's Certification").

Phase I – Authorization to Proceed and Document Gathering

Ranger was authorized to proceed with the Engineer's Certification in December 2015 (as Tamarack Consulting, LLC). The initial construction documentation was provided by the District January 11, 2016. Subsequent supporting documentation for Phase II construction improvements was delivered by the District through the current cost certification.

Phase II – Site Visit and Meetings

Ranger has performed site visits to verify completion of work relating to District infrastructure during Phase II construction improvements. The site visits were to verify general conformance with contract documents and does not guarantee quality or acceptance of public improvements.

Phase III – Review of Documentation

Documentation was requested at the beginning of work. Requested documentation include the following:

- Executed Contracts and Bid Tabs
- Approved Construction Drawings
- Acceptable Proof of Payment (Cancelled checks and bank statements or lien waivers)
- Invoices and/or Pay Applications
- Approved changes or amendments to contract documents
- Copies of any agreements that will impact District funding

See Appendix A for a complete listing of documents reviewed, as deemed necessary, by Ranger.

Phase IV – Verification of Construction Quantities

Construction quantity take-offs were performed from applicable construction drawings. These quantity take-offs were used in conjunction with Phase V below to certify reasonableness of construction costs.

Phase V – Verification of Construction Unit Costs and Indirect Costs

Construction Unit Costs and Indirect Costs were reviewed for market reasonableness. Ranger took into consideration the type of construction and the timeframe during which the construction occurred. Ranger determined that the costs incurred were within a reasonable range.

Phase VI – Verification of Payment for Public Costs

Per current agreements, District funded costs are approved before payment is made. Contractors and consultants are to provide Conditional Lien Release Waivers for the amount of payment requested. After payment is made, the contractors and consultants are to provide Unconditional Lien Release Waivers. When applicable, cancelled checks and bank statements are also used to verify proof of payment. Certain soft and indirect costs that have portions that are both publicly and privately funded but have not yet been paid are included in this certification. These costs are clearly identified in Table VII Soft and Indirect Costs Detail in the District and Developer Disbursement columns. These costs are included in order to identify the public and private costs and assign these costs to either the Developer or the District. The proof of payment in the form of cancelled checks and bank statements will be reviewed as payments are processed and reflected on future certifications.

Phase VII – Determination of Costs Eligible for Reimbursement

Ranger concluded the Engineer's Certification by determining which improvements were eligible for District and Town reimbursement and what percent of the costs for those improvements were reimbursable.

Cost Certification Phase II construction improvements that were reimbursable consisted of roadways, paths, & hardscape and temporary conditions.

In Cost Certification #24, an Xcel fee was determined eligible in the amount of \$72,886.93. This cost shows up on two separate District funding requests. A check was originally written to pay this fee but was canceled. After verification of the costs, the District wrote another check to pay for this fee per the June funding request, even though this cost was certified on Cost Certification #24.

A fee for American Fence directly paid by Lee Merritt of Ranch Capital was duplicated on Cost Certifications #24 and #25. There is a deduction on Cost Certification #26 to reconcile the overall costs paid to American Fence.

The Town of Superior provided a contribution of \$198,795.49 directly to the funding of the McCaslin Roundabout scope of work performed by Hall Irwin Corporation. On Cost Certification #27, a credit was identified for this amount to be applied to District costs. This credit did not impact the amount of reimbursable costs for the Town. The intent of this credit is to show the financial impact of the Town directly providing these funds.

Hudick Excavating Inc. ("HEI") provided Pay Application 1 directly to the District and Pay Application 2 to the Developer. The funding for these pay applications was allocated separately, but the costs were still determined to be District eligible.

On Cost Certification #31, Samora Construction Contract, costs were submitted for work related to Superior Roadway, which had the top 2" lift fail. Samora issued a credit in the amount of \$9,975 for the 2" failure on Cost Certification #32. When this work is accepted, the full line item will be billed. Costs submitted deemed District eligible for Ninyo & Moore on Cost Certification #20 were realized to be partially non-District. A negative cost of (-\$2,984.79) was identified on Cost Certification #31 to adjust for the non-District costs previously certified.

On Cost Certification #33, adjustments were made to account for errors in prior Cost Certification reports that were identified after performing an audit of certified costs to date. A Cut Above had duplicate costs certified on Certifications #21 and #22. There was a Special District Management Services, Inc invoice that was incorrectly captured as Capital costs as well. Lastly, there were various vendor invoices that were not included in final reports, and those costs were captured at this time.

During the review of Cost Certification #34, the Town notified associated parties that costs associated with the Medical Office Building Garage would not be eligible under SURA until approved by the Town Board, per Resolution No. R-36. Garage costs are currently determined to be District eligible and will become SURA eligible upon the Town Board approval.

System Development Fee backup was provided with Cost Certification #41 backup, but the costs were not included in the report, pending comments and coordination between the Town and the District.

In February 2019, the Town reviewed costs that had been applied to the *Public Park Amenities and Facilities* Town Category. Miscellaneous line items that were labeled under this category were updated to different Town Categories. The impact was that \$14,209.35 was reallocated to *Mob & Temporary Conditions*, \$719,328.02 was reallocated to *Roadways, Paths, & Hardscape*, and \$780,200.89 was reallocated from *Park Site Development* to *Public Park Amenities and Facilities*.

On Cost Certification #48, System Development fees were certified for the first time. Fees related to SDC – Planning Area 3 Residential were only District eligible, while fees related to SDC – Planning Area 1 and 2 Residential and Commercial, as well as SDC – Planning Area 3 Commercial were considered District and Town eligible.

ENGINEER'S CERTIFICATION

Collin D Koranda, P.E. / Ranger Engineering, LLC (the "Independent Consulting Engineer"), states as follows:

1. The Independent Consulting Engineer is an engineer duly qualified and licensed in the State of Colorado with experience in the design, construction and certification of Public Improvements of similar type and function as those described in the above Engineer's Report.

2. The Independent Consulting Engineer has performed a site visit and reviewed applicable construction and legal documents related to the Public Improvements under consideration to state the conclusions set forth in this Engineer's Certification.

3. The Independent Consulting Engineer finds and determines that the constructed value of the Public Improvements considered in the attached Engineer's Report dated May 24, 2019 including soft and indirect, District funded, and hard costs, are valued at an estimated **\$2,993,588.74**. In the opinion of the Independent Consulting Engineer, the above stated estimated value for the Public Improvements is reasonable and consistent with costs of similar improvements constructed for similar purposes during the same timeframe in similar locales.

Sincerely,

Ranger Engineering, LLC

A handwritten signature in blue ink, appearing to read "Collin D. Koranda".

Collin D. Koranda, P. E.

APPENDIX A

Documents Reviewed

Agreements

- Cost Sharing Agreement between Superior Urban Renewal Authority, RC Superior, LLC, and STC Metropolitan District No 1, 2 and 3. Dated October 18, 2013.
- Development Agreement between the Town of Superior, CO, the Superior Metropolitan District No. 1, the Superior Urban Renewal Authority, and RC Superior LLC. Dated March 11, 2013.
- Public Finance Agreement between the Superior Urban Renewal Authority, the Superior McCaslin Interchange Metropolitan District, RC Superior LLC, and the Town of Superior, CO. Dated March 15, 2013.
- Cost Sharing and Reimbursement Agreement between Aweida Properties and STC Metropolitan District No. 2. Dated October 21, 2015.

Construction Plans

- Final Development Plan – Phase I Superior Town Center Infrastructure Plans. Prepared by Civil Resources LLC. Dated November 12, 2013.
- Final Development Plan #1 – Phase I Street Paving Plans. Prepared by Civil Resources LLC. Dated April 29, 2016.
- Final Plat Superior Town Center Filing No. 1B. Prepared by Civil Resources LLC. Dated December 4, 2013.
- Overlot Grading and Stormwater Management Plans for Superior Town Center Phase 1A. Prepared by Civil Resources LLC. Released for construction May 22, 2015.
- Superior Town Center Phase I Utility Infrastructure Plans. Prepared by Civil Resources LLC. Issued for Construction August 20, 2015.
- Town of Superior Town Center Lift Station Final Drawings Set 1 & Set 2 Rev 0. Prepared by Dewberry Engineers Inc. Dated July 25, 2014.
- Town of Superior McCaslin Blvd. Town Center Left Turn Lane Drawings. Dated February 24, 2016.
- Superior Town Center – Construction Plans – Phase 3 (McCaslin Roundabout). Prepared by Civil Resources Inc. Dated August 12, 2016. Accepted by Public Works September 9, 2016.
- Final Development Plan 1 – Phase 4 (Marshall Road Extension) – Construction Plans – Superior Town Center. Dated August 19, 2016.

Invoices

- Samora Construction Invoice 658. Dated 4/30/19.
- Samora Construction Pay Application 2-654. Dated 4/30/19.
- Hudick Excavating Inc. Pay Application 19. Dated 4/30/19.
- Down To Earth Compliance Invoices 48106, 48136, 48142, 48196, & 48221. Dated 4/11/19 – 4/30/19.

For soft and indirect costs, district funded costs, and System Development Fees reviewed, refer to Tables VIII, IX, and X.

Service Plan

- Superior Town Center Metropolitan District No. 2. Prepared by McGeedy Sisneros, P.C. and dated May 13, 2013.



SUPERIOR TOWN CENTER METROPOLITAN DISTRICT

Project Costs Summary for District and Town

Table II

	Total Cost Invoiced	Maximum Eligible Costs	District Eligible Costs	Town Eligible Costs
Direct Construction Costs	\$ 431,826.84	\$ 324,591.35	\$ 324,591.35	\$ 319,876.35
Soft and Indirect Costs	\$ 891,082.13	\$ 105,426.04	\$ 105,426.04	\$ 105,426.04
District Funded Costs	\$ 35,430.29	\$ 7,216.95	\$ 7,216.95	\$ 7,216.95
System Development Costs	\$ 2,556,354.40	\$ 2,556,354.40	\$ 2,556,354.40	\$ 474,904.40
Totals	\$ 3,914,693.66	\$ 2,993,588.74	\$ 2,993,588.74	\$ 907,423.74



SUPERIOR TOWN CENTER METROPOLITAN DISTRICT

Construction Costs Summary By Category

Table III

Category	Total Eligible Soft Costs	Category Percentage
Total Town Eligible Costs		
Earthwork	\$ -	0.0%
Roadways, Paths, & Hardscape	\$ 11,234.06	3.6%
Offsite Roadways	\$ -	0.0%
Walls and Structures	\$ -	0.0%
Storm Sewer	\$ 91,010.00	29.1%
Sanitary Sewer	\$ 144,377.20	46.1%
Reuse Water & Irrigation Piping	\$ -	0.0%
Domestic Water	\$ -	0.0%
Dry Utilities	\$ -	0.0%
Park Site Development	\$ 14,440.00	4.6%
Mob & Temporary Conditions	\$ 52,141.03	16.6%
SDC - Planning Area 1 and 2	\$ -	0.0%
SDC - Planning Area 3	\$ -	0.0%
Parking & Architectural Enhancement	\$ -	0.0%
Public Park Amenities & Facilities	\$ -	0.0%
Not Eligible	\$ -	0.0%
	\$ 313,202.29	100.0%
Total District Eligible Costs		
Operation	\$ -	0.0%
Capital	\$ 315,559.79	100.0%
Non District	\$ -	0.0%
	\$ 315,559.79	100.0%



SUPERIOR TOWN CENTER METROPOLITAN DISTRICT

Soft Costs Summary By Category

Table IV

Category	Total Eligible Soft Costs	Category Percentage
Total Town Eligible Costs		
Earthwork	\$ -	0.0%
Roadways, Paths, & Hardscape	\$ 75,572.07	71.7%
Offsite Roadways	\$ -	0.0%
Walls and Structures	\$ -	0.0%
Storm Sewer	\$ -	0.0%
Sanitary Sewer	\$ -	0.0%
Reuse Water & Irrigation Piping	\$ -	0.0%
Domestic Water	\$ -	0.0%
Dry Utilities	\$ -	0.0%
Park Site Development	\$ 3,059.25	2.9%
Mob & Temporary Conditions	\$ 3,566.20	3.4%
SDC - Planning Area 1 and 2	\$ -	0.0%
SDC - Planning Area 3	\$ -	0.0%
Parking & Architectural Enhancement	\$ -	0.0%
Public Park Amenities & Facilities	\$ -	0.0%
Other Eligible Costs	\$ 23,228.52	22.0%
Not Eligible	\$ -	0.0%
	\$ 105,426.04	100.0%
Total District Eligible Costs		
Organization	\$ -	0.0%
Operation	\$ -	0.0%
Capital	\$ 105,426.04	100.0%
	\$ 105,426.04	100.0%



SUPERIOR TOWN CENTER METROPOLITAN DISTRICT

District Funded Costs Summary

Table V

Category	Total Eligible Soft Costs		Category Percentage
Total Town Eligible Costs			
Earthwork	\$	-	0.0%
Roadways, Paths, & Hardscape	\$	-	0.0%
Offsite Roadways	\$	-	0.0%
Walls and Structures	\$	-	0.0%
Storm Sewer	\$	-	0.0%
Sanitary Sewer	\$	-	0.0%
Reuse Water & Irrigation Piping	\$	-	0.0%
Domestic Water	\$	-	0.0%
Dry Utilities	\$	-	0.0%
Park Site Development	\$	-	0.0%
Mob & Temporary Conditions	\$	-	0.0%
SDC - Planning Area 1 and 2	\$	-	0.0%
SDC - Planning Area 3	\$	-	0.0%
Parking & Architectural Enhancement	\$	-	0.0%
Public Park Amenities & Facilities	\$	-	0.0%
Other Eligible Costs	\$	7,216.95	100.0%
Not Eligible	\$	-	0.0%
	\$	7,216.95	100.0%
Total District Eligible Costs			
Operation	\$	-	0.0%
Capital	\$	7,216.95	100.0%
Organization	\$	-	0.0%
	\$	7,216.95	100.0%



SUPERIOR TOWN CENTER METROPOLITAN DISTRICT

System Development Fee Costs Summary

Table VI

Category	Total Eligible Soft Costs		Category Percentage
Total Town Eligible Costs			
Earthwork	\$	-	0.0%
Roadways, Paths, & Hardscape	\$	-	0.0%
Offsite Roadways	\$	-	0.0%
Walls and Structures	\$	-	0.0%
Storm Sewer	\$	-	0.0%
Sanitary Sewer	\$	-	0.0%
Reuse Water & Irrigation Piping	\$	-	0.0%
Domestic Water	\$	-	0.0%
Dry Utilities	\$	-	0.0%
Park Site Development	\$	-	0.0%
Mob & Temporary Conditions	\$	-	0.0%
SDC - Planning Area 1 and 2	\$	474,904.40	100.0%
SDC - Planning Area 3	\$	-	0.0%
Parking & Architectural Enhancement	\$	-	0.0%
Public Park Amenities & Facilities	\$	-	0.0%
Other Eligible Costs	\$	-	0.0%
Not Eligible	\$	-	0.0%
	\$	474,904.40	100.0%
Total District Eligible Costs			
Operation	\$	-	0.0%
Capital	\$	2,556,354.40	100.0%
Organization	\$	-	0.0%
	\$	2,556,354.40	100.0%



SUPERIOR TOWN CENTER METROPOLITAN DISTRICT
Soft and Indirect Costs
Table VIII

Vendor	Invoice Number	Invoices Description	Date	Amount Invoiced	District Category	District Powers	Town Categories	Percent District Eligible	Amount District Eligible	Percent Town Eligible	Amount Town Eligible	Total Eligible	Certification Number
505 Design, Inc.	11867	Superior Sign Planning & Design - Phase 2	04/30/19	\$ 500.00	Capital	Street	Roadways, Paths, & Hardscape	100%	\$ 500.00	100%	\$ 500.00	100%	48
Cesare, Inc	17.3079.20	Storm Sewer and Materials testing / FDP 1 Phase 2B Streets	04/25/19	\$ 151.50	Capital	Street	Roadways, Paths, & Hardscape	100%	\$ 151.50	100%	\$ 151.50	100%	48
Cesare, Inc	19.3035.1	Block 25 Phase 2	04/29/19	\$ 8,123.00	Capital	Street	Roadways, Paths, & Hardscape	100%	\$ 8,123.00	100%	\$ 8,123.00	100%	48
Civil Resources, LLC	238.001.01.63	Superior Town Center - Infrastructure	05/01/19	\$ 23,228.52	Capital	Multiple	Other Eligible Costs	100%	\$ 23,228.52	100%	\$ 23,228.52	100%	48
Moore Iacofano Goltsman, Inc.	0058281	STC - FDP 3 Phase 3	04/25/19	\$ 797.50	Capital	Street	Roadways, Paths, & Hardscape	100%	\$ 797.50	100%	\$ 797.50	100%	48
Moore Iacofano Goltsman, Inc.	0058282	STC - FDP 1 Phase 2B	04/25/19	\$ 3,059.25	Capital	Parks and Recreation	Park Site Development	100%	\$ 3,059.25	100%	\$ 3,059.25	100%	48
Rush Management	125938	Street Sweeping	03/31/19	\$ 2,640.00	Capital	Multiple	Mob & Temporary Conditions	47%	\$ 1,240.80	47%	\$ 1,240.80	47%	48
Rush Management	126389	Street Sweeping	04/30/19	\$ 2,820.00	Capital	Multiple	Mob & Temporary Conditions	47%	\$ 1,325.40	47%	\$ 1,325.40	47%	48
Summit Services	26448	Stormwater Inseption	03/29/19	\$ 400.00	Capital	Multiple	Mob & Temporary Conditions	100%	\$ 400.00	100%	\$ 400.00	100%	48
Summit Services	26766	Stormwater Inseption	04/30/19	\$ 600.00	Capital	Multiple	Mob & Temporary Conditions	100%	\$ 600.00	100%	\$ 600.00	100%	48
Town of Superior	864	FDP #1 Infrastructure	04/26/19	\$ 28,641.69	Capital	Multiple	Roadways, Paths, & Hardscape	100%	\$ 28,641.69	100%	\$ 28,641.69	100%	48
Town of Superior	865	Planning Area 3 (Toll Bros)	04/26/19	\$ 7,624.50	Capital	Multiple	Roadways, Paths, & Hardscape	100%	\$ 7,624.50	100%	\$ 7,624.50	100%	48
Town of Superior	Email	ROW Permits - Block 25 and 26	04/26/19	\$ 15,455.18	Capital	Street	Roadways, Paths, & Hardscape	100%	\$ 15,455.18	100%	\$ 15,455.18	100%	48
Town of Superior	Email	ROW Permits - McCaslin and Marshall	04/30/19	\$ 14,278.70	Capital	Street	Roadways, Paths, & Hardscape	100%	\$ 14,278.70	100%	\$ 14,278.70	100%	48
Xcel Energy	637347166	Non-Recurring Chargs - 8" Gas Main	05/08/19	\$ 782,762.29	Non District	Non District	Not Eligible	0%	\$ -	0%	\$ -	0%	48
				\$ 891,082.13					\$ 105,426.04		\$ 105,426.04		



SUPERIOR TOWN CENTER METROPOLITAN DISTRICT
District Funded Costs
Table IX

Vendor	Invoice Number	Invoices Description	Date	Amount Invoiced	District Category	District Powers	Town Categories	Percent District	Amount District	Percent Town	Amount Town	Total	District	District
								Eligible	Eligible	Eligible	Eligible	Eligible	Capital Costs	Operations Costs
Comcast	316389	Parking Structure	05/09/19	\$ 139.97	Operation	Non District	Not Eligible	0%	\$ -	0%	\$ -	0%	\$ -	\$ 139.97
Doody Calls	21097, 21726	Pet Waste Removal	02/28/19	\$ 120.00	Operation	Non District	Not Eligible	0%	\$ -	0%	\$ -	0%	\$ -	\$ 120.00
Manhard Consulting	42999	GIS Management	04/16/19	\$ 450.00	Capital	Multiple	Other Eligible Costs	100%	\$ 450.00	100%	\$ 450.00	100%	\$ 450.00	\$ -
McGeady Becher P.C.	11098 Mar 19	Legal fees for operations related matters	03/31/19	\$ 2,527.28	Operation	Non District	Not Eligible	0%	\$ -	0%	\$ -	0%	\$ -	\$ 2,527.28
McGeady Becher P.C.	11098 Mar 19	Legal fees for capital related matters	03/31/19	\$ 3,609.52	Capital	Multiple	Other Eligible Costs	100%	\$ 3,609.52	100%	\$ 3,609.52	100%	\$ 3,609.52	\$ -
Ranger Engineering, LLC	0055	Cost Certification Services	03/29/19	\$ 2,625.00	Capital	Multiple	Other Eligible Costs	100%	\$ 2,625.00	100%	\$ 2,625.00	100%	\$ 2,625.00	\$ -
Simmons & Wheeler, P.C.	24165	Accounting Services - Operations	03/31/19	\$ 532.43	Operation	Non District	Not Eligible	0%	\$ -	0%	\$ -	0%	\$ -	\$ 532.43
Simmons & Wheeler, P.C.	24165	Accounting Services - Capital	03/31/19	\$ 532.43	Capital	Multiple	Other Eligible Costs	100%	\$ 532.43	100%	\$ 532.43	100%	\$ 532.43	\$ -
Special District Management Services	Mar 2019	District Management Services	03/31/19	\$ 5,561.25	Operation	Non District	Not Eligible	0%	\$ -	0%	\$ -	0%	\$ -	\$ 5,561.25
Thyssenkrupp Elevator Corp	3004485596	Parking Structure	04/01/19	\$ 165.00	Operation	Non District	Not Eligible	0%	\$ -	0%	\$ -	0%	\$ -	\$ 165.00
Town of Superior	Src 2289, 438	Irrigation Costs	04/11/19	\$ 17.88	Operation	Non District	Not Eligible	0%	\$ -	0%	\$ -	0%	\$ -	\$ 17.88
UMB Bank	642129	Administrative Fees	04/10/19	\$ 4,000.00	Operation	Non District	Not Eligible	0%	\$ -	0%	\$ -	0%	\$ -	\$ 4,000.00
Vargas Property Services	28249-28401	Contract Maintenance, Trash, Watering	04/01/19	\$ 14,465.80	Operation	Non District	Not Eligible	0%	\$ -	0%	\$ -	0%	\$ -	\$ 14,465.80
Xcel Energy	2852-3428	Monthly Service	04/18/19	\$ 683.73	Operation	Non District	Not Eligible	0%	\$ -	0%	\$ -	0%	\$ -	\$ 683.73
				\$ 35,430.29				\$ 7,216.95	\$ 7,216.95	\$ 7,216.95	\$ 7,216.95	\$ 28,213.34		



SUPERIOR TOWN CENTER METROPOLITAN DISTRICT
System Development Fee Costs

Table X

Builder Name	Invoice Number	Description	Type	Date	Amount Invoiced	Paid By	Proof of Payment				District Category	District Powers	Town Categories	Percent District	Amount District	Percent Town	Amount Town
							Check No	Check Written	Check Cleared	Amount Paid				Eligible	Eligible	Eligible	Eligible
Wonderland Homes	52495	Block 13, Lots 62-65	Residential	05/31/17	\$ 84,081.00	RC Superior, LLC	Wire	05/31/17	05/31/17	\$ 84,081.00	Capital	Multiple	SDC - Planning Area 3	100%	\$ 84,081.00	0%	\$ -
Remington Homes	52496	Block 13, Lots 1-6	Residential	06/13/17	\$ 135,414.00	RC Superior, LLC	Wire	06/13/17	06/13/17	\$ 135,414.00	Capital	Multiple	SDC - Planning Area 3	100%	\$ 135,414.00	0%	\$ -
Remington Homes	52497	Block 13, Lots 7-10	Residential	07/18/17	\$ 90,276.00	RC Superior, LLC	Wire	07/18/17	07/18/17	\$ 90,276.00	Capital	Multiple	SDC - Planning Area 3	100%	\$ 90,276.00	0%	\$ -
Wonderland Homes	52498	Block 13, Lots 66-68	Residential	08/23/17	\$ 63,577.00	RC Superior, LLC	Wire	08/23/17	08/23/17	\$ 63,577.00	Capital	Multiple	SDC - Planning Area 3	100%	\$ 63,577.00	0%	\$ -
Superior JL LLC	52494	Block 1, Lot 3A	Commercial	08/29/17	\$ 474,904.40	RC Superior, LLC	Wire	08/29/17	08/29/17	\$ 474,904.40	Capital	Multiple	SDC - Planning Area 1 and 2	100%	\$ 474,904.40	100%	\$ 474,904.40
Remington Homes	52493	Block 13, Lots 42-48	Residential	09/26/17	\$ 155,918.00	RC Superior, LLC	Wire	09/26/17	09/26/17	\$ 155,918.00	Capital	Multiple	SDC - Planning Area 3	100%	\$ 155,918.00	0%	\$ -
Remington Homes	52499	Block 13, Lots 24-31	Residential	11/01/17	\$ 176,422.00	RC Superior, LLC	Wire	11/01/17	11/01/17	\$ 176,422.00	Capital	Multiple	SDC - Planning Area 3	100%	\$ 176,422.00	0%	\$ -
Wonderland Homes	52500	Block 13, Lots 69-71	Residential	11/10/17	\$ 63,577.00	RC Superior, LLC	Wire	11/10/17	11/10/17	\$ 63,577.00	Capital	Multiple	SDC - Planning Area 3	100%	\$ 63,577.00	0%	\$ -
Remington Homes	52501	Block 13, Lots 32-34	Residential	12/06/17	\$ 67,707.00	RC Superior, LLC	Wire	12/06/17	12/06/17	\$ 67,707.00	Capital	Multiple	SDC - Planning Area 3	100%	\$ 67,707.00	0%	\$ -
Remington Homes	52529	550 Superior Drive (86)	Residential	01/03/18	\$ 28,573.00	RC Superior, LLC	Wire	01/03/18	01/03/18	\$ 28,573.00	Capital	Multiple	SDC - Planning Area 3	100%	\$ 28,573.00	0%	\$ -
Remington Homes	52528	530 Superior Drive (84)	Residential	01/03/18	\$ 28,573.00	RC Superior, LLC	Wire	01/03/18	01/03/18	\$ 28,573.00	Capital	Multiple	SDC - Planning Area 3	100%	\$ 28,573.00	0%	\$ -
CDL Homes (WH)	52505	Block 13, Lots 72-74	Residential	01/16/18	\$ 63,577.00	RC Superior, LLC	Wire	01/16/18	01/16/18	\$ 63,577.00	Capital	Multiple	SDC - Planning Area 3	100%	\$ 63,577.00	0%	\$ -
Remington Homes	52506	Block 13, Lot 90	Residential	01/17/18	\$ 28,573.00	RC Superior, LLC	Wire	01/17/18	01/17/18	\$ 28,573.00	Capital	Multiple	SDC - Planning Area 3	100%	\$ 28,573.00	0%	\$ -
Remington Homes	52507	Block 13, Lot 88	Residential	01/17/18	\$ 28,573.00	RC Superior, LLC	Wire	01/17/18	01/17/18	\$ 28,573.00	Capital	Multiple	SDC - Planning Area 3	100%	\$ 28,573.00	0%	\$ -
Remington Homes	52508	Block 13, Lots 35-41	Residential	01/31/18	\$ 151,788.00	RC Superior, LLC	Wire	01/31/18	01/31/18	\$ 151,788.00	Capital	Multiple	SDC - Planning Area 3	100%	\$ 151,788.00	0%	\$ -
Wonderland Homes	52509	Block 13, Lots 75-78	Residential	02/14/18	\$ 84,081.00	RC Superior, LLC	Wire	02/14/18	02/14/18	\$ 84,081.00	Capital	Multiple	SDC - Planning Area 3	100%	\$ 84,081.00	0%	\$ -
Remington Homes	52510	Block 13, Lot 87	Residential	02/28/18	\$ 28,573.00	RC Superior, LLC	Wire	02/28/18	02/28/18	\$ 28,573.00	Capital	Multiple	SDC - Planning Area 3	100%	\$ 28,573.00	0%	\$ -
Remington Homes	52511	Block 13, Lot 79	Residential	03/24/18	\$ 30,679.00	RC Superior, LLC	Wire	03/24/18	03/24/18	\$ 30,679.00	Capital	Multiple	SDC - Planning Area 3	100%	\$ 30,679.00	0%	\$ -
Remington Homes	52512	Block 13, Lot 81, 83, 85	Residential	04/11/18	\$ 92,037.00	RC Superior, LLC	Wire	04/11/18	04/11/18	\$ 92,037.00	Capital	Multiple	SDC - Planning Area 3	100%	\$ 92,037.00	0%	\$ -
Wonderland Homes	52514	Block 13, Lots 18-20	Residential	04/19/18	\$ 66,009.00	RC Superior, LLC	Wire	04/19/18	04/19/18	\$ 66,009.00	Capital	Multiple	SDC - Planning Area 3	100%	\$ 66,009.00	0%	\$ -
Wonderland Homes	52514	Block 13, Lots 21-25	Residential	04/19/18	\$ 112,235.00	RC Superior, LLC	Wire	04/19/18	04/19/18	\$ 112,235.00	Capital	Multiple	SDC - Planning Area 3	100%	\$ 112,235.00	0%	\$ -
Remington Homes	52515	Block 13, Lot 91	Residential	05/09/18	\$ 28,573.00	RC Superior, LLC	Wire	05/09/18	05/09/18	\$ 28,573.00	Capital	Multiple	SDC - Planning Area 3	100%	\$ 28,573.00	0%	\$ -
Remington Homes	52516	Block 13, Lot 91	Residential	05/17/18	\$ 2,106.00	RC Superior, LLC	Wire	05/17/18	05/17/18	\$ 2,106.00	Capital	Multiple	SDC - Planning Area 3	100%	\$ 2,106.00	0%	\$ -
Remington Homes	52517	Block 13, Lot 89	Residential	05/30/18	\$ 30,679.00	RC Superior, LLC	Wire	05/30/18	05/30/18	\$ 30,679.00	Capital	Multiple	SDC - Planning Area 3	100%	\$ 30,679.00	0%	\$ -
Wonderland Homes	52518	Block 25, Lots 15-17	Residential	06/12/18	\$ 66,009.00	RC Superior, LLC	Wire	06/12/18	06/12/18	\$ 66,009.00	Capital	Multiple	SDC - Planning Area 3	100%	\$ 66,009.00	0%	\$ -
Remington Homes	52519	Block 13, Lot 80	Residential	07/25/18	\$ 30,679.00	RC Superior, LLC	Wire	07/25/18	07/25/18	\$ 30,679.00	Capital	Multiple	SDC - Planning Area 3	100%	\$ 30,679.00	0%	\$ -
Wonderland Homes	52520	Block 25, Lots 12-14	Residential	08/02/18	\$ 66,009.00	RC Superior, LLC	Wire	08/02/18	08/02/18	\$ 66,009.00	Capital	Multiple	SDC - Planning Area 3	100%	\$ 66,009.00	0%	\$ -
Wonderland Homes	52521	Block 24, Lots 8-11	Residential	08/12/18	\$ 90,232.00	RC Superior, LLC	Wire	08/12/18	08/12/18	\$ 90,232.00	Capital	Multiple	SDC - Planning Area 3	100%	\$ 90,232.00	0%	\$ -
Remington Homes	52522	Block 13, Lot 82	Residential	08/28/18	\$ 30,679.00	RC Superior, LLC	Wire	08/28/18	08/28/18	\$ 30,679.00	Capital	Multiple	SDC - Planning Area 3	100%	\$ 30,679.00	0%	\$ -
Wonderland Homes	52523	Block 25, Lots 5-7	Residential	09/14/18	\$ 66,009.00	RC Superior, LLC	Wire	09/14/18	09/14/18	\$ 66,009.00	Capital	Multiple	SDC - Planning Area 3	100%	\$ 66,009.00	0%	\$ -
Wonderland Homes	52488	Block 24, Lots 1-4	Residential	09/24/18	\$ 90,232.00	RC Superior, LLC	Wire	09/24/18	09/24/18	\$ 90,232.00	Capital	Multiple	SDC - Planning Area 3	100%	\$ 90,232.00	0%	\$ -
THB Superior LLC (Thrive)		Block 26, Lots 1-3	Residential	03/24/19	\$ 90,642.00	RC Superior, LLC	Wire	03/24/19	03/24/19	\$ 90,642.00	Capital	Multiple	SDC - Planning Area 3	100%	\$ 90,642.00	0%	\$ -
TH Superior MF LLC		Block 26, Lots 4-7	Residential	04/25/19	\$ 120,856.00	RC Superior, LLC	Wire	04/25/19	04/25/19	\$ 120,856.00	Capital	Multiple	SDC - Planning Area 3	100%	\$ 120,856.00	0%	\$ -
					\$ 2,556,354.40				\$ 2,556,354.40					\$ 2,556,354.40		\$ 474,904.40	